



CE EMC Test Report

Issued date: Jul. 17, 2024

Project No.: 24Q050601

Product : Edge AI Computing System

Model : EAC-6200

Series Model : EAC-6000 Series, EAC-6XXXXXXXXXXXXXXXXXXXXXXX ("X" can be 0-9, A-Z, - or blank for marketing purpose)

Applicant : Vecow Co., Ltd

Address : 3F, No. 10, Jiankang Rd., Zhonghe Dist., New Taipei City 23586, Taiwan

Report No: WD-EE-R-240206-A0

According to

- | | |
|---|--------------------------------|
| EN 55032: 2015 + A11: 2020, Class A | IEC 61000-4-2: 2008 |
| BS EN 55032: 2015 + A11: 2020 | IEC 61000-4-3: 2020 |
| CISPR 32: 2015 | IEC 61000-4-4: 2012 |
| AS/NZS CISPR 32: 2015 | IEC 61000-4-5: 2014 + A1: 2017 |
| EN 61000-3-2: 2014 | IEC 61000-4-6: 2013 |
| EN IEC 61000-3-2: 2019 + A1: 2021 | IEC 61000-4-8: 2009 |
| EN 61000-3-3: 2013 + A2: 2021 | IEC 61000-4-11: 2020 |
| BS EN 61000-3-2: 2014 | EN 61000-4-2: 2009 |
| BS EN IEC 61000-3-2: 2019 + A1: 2021 | EN IEC 61000-4-3: 2020 |
| BS EN 61000-3-3: 2013 + A2: 2021 | EN 61000-4-4: 2012 |
| EN 55035: 2017 + A11: 2020 | EN 61000-4-5: 2014 + A1: 2017 |
| BS EN 55035: 2017 + A11: 2020 | EN 61000-4-6: 2014 + AC: 2015 |
| | EN 61000-4-8: 2010 |
| | EN IEC 61000-4-11: 2020 |

Authorized Signatory :  / Ken Huang



Wendell Industrial Co., Ltd
Wendell EMC & RF Laboratory

Add: 5F-1, No. 188, Baoqiao Road, Xindian District, New Taipei City 23145, Taiwan R.O.C.



Table of Contents

1	Certification	7
1.1	Summary of Test Result.....	8
2	Test Configuration of Equipment Under Test	9
2.1	Test Facility.....	9
2.2	Measurement Uncertainty	10
2.2.1	Conducted Emission test.....	10
2.2.2	Conducted emission at telecom port test	10
2.2.3	Radiated Emission test.....	10
3	General Information.....	11
3.1	Description of EUT.....	11
3.2	Description of Test Modes.....	12
3.3	EUT Operating Condition	12
3.4	Description of Support Unit	13
3.5	Configuration of System Under Test.....	14
4	Emission Test.....	15
4.1	Conducted Emission Measurement	15
4.1.1	Limit of Conducted Emission Measurement	15
4.1.2	Test Instrument	16
4.1.3	Test Procedure.....	17
4.1.4	Deviation from Test Standard	17
4.1.5	Test Setup.....	18
4.1.6	Test Result	19
4.1.7	Photographs of Test Configuration	23
4.2	Conducted Emission at Telecommunication Ports Test	24
4.2.1	Limit of Conducted Emission at Telecommunication Ports Test.....	24
4.2.2	Test Instrument	26
4.2.3	Test Procedure.....	27
4.2.4	Deviation from Test Standard	27
4.2.5	Test Setup.....	28
4.2.6	Test Result	29
4.2.7	Photographs of Test Configuration	33
4.3	Radiated Emission Measurement	35
4.3.1	Limits of Radiated Emission Measurement.....	35
4.3.2	Test Instrument	37
4.3.3	Test Procedure.....	38
4.3.4	Deviation from Test Standard	38
4.3.5	Test Setup.....	39
4.3.6	Test Result	42
4.3.7	Photographs of Test Configuration	46
4.4	Harmonics Current Measurement.....	48
4.4.1	Limits of Harmonics Current Measurement	48
4.4.2	Test Instrument	48
4.4.3	Test Procedure.....	49
4.4.4	Deviation from Test Standard	50
4.4.5	Test Setup.....	50
4.4.6	Test Result	51

4.4.7	Photographs of Test Configuration	52
4.5	Voltage Fluctuation and Flicker Measurement	53
4.5.1	Limit for Voltage Function and Flicker Measurement.....	53
4.5.2	Test Instrument	53
4.5.3	Test Procedure.....	53
4.5.4	Deviation from Test Standard	53
4.5.5	Test Setup.....	54
4.5.6	Test Result	55
4.5.7	Photographs of Test Configuration	56
5	Immunity Test	57
5.1	Standard Description	57
5.2	Performance Criteria.....	58
5.3	Electrostatic Discharge (ESD).....	59
5.3.1	Test Specification.....	59
5.3.2	Test Instrument	59
5.3.3	Test Procedure.....	60
5.3.4	Deviation from Test Standard	61
5.3.5	Test Setup.....	61
5.3.6	Test Result	63
5.3.7	Photographs of Test Configuration	68
5.4	Radiated, Radio-frequency, Electromagnetic Field Immunity Test (RS).....	69
5.4.1	Test Specification.....	69
5.4.2	Test Instrument	70
5.4.3	Test Procedure.....	71
5.4.4	Deviation from Test Standard	71
5.4.5	Test Setup.....	72
5.4.6	Test Result	73
5.4.7	Photographs of Test Configuration	74
5.5	Electrical Fast Transient /Burst Immunity Test (EFT)	75
5.5.1	Test Specification.....	75
5.5.2	Test Instrument	75
5.5.3	Test Procedure.....	76
5.5.4	Deviation from Test Standard	76
5.5.5	Test Setup.....	77
5.5.6	Test Result	78
5.5.7	Photographs of Test Configuration	79
5.6	Surge Immunity Test.....	81
5.6.1	Test Specification.....	81
5.6.2	Test Instrument	82
5.6.3	Test Procedure.....	82
5.6.4	Deviation from Test Standard	83
5.6.5	Test Setup.....	83
5.6.6	Test Result	84
5.6.7	Photographs of Test Configuration	85
5.7	Continuous Conducted Disturbances (CS)	86
5.7.1	Test Specification.....	86
5.7.2	Test Instrument	86
5.7.3	Test Procedure.....	87
5.7.4	Deviation from Test Standard	88



5.7.5 Test Setup..... 88

5.7.6 Test Result 89

5.7.7 Photographs of Test Configuration 90

5.8 Power Frequency Magnetic Field Immunity Test 92

5.8.1 Test Specification..... 92

5.8.2 Test Instrument 92

5.8.3 Test Procedure..... 92

5.8.4 Deviation from Test Standard 92

5.8.5 Test Setup..... 93

5.8.6 Test Result 94

5.8.7 Photographs of Test Configuration 95

5.9 Voltage Dips & Short Interruptions 96

5.9.1 Test Specification..... 96

5.9.2 Test Instrument 96

5.9.3 Test Procedure..... 97

5.9.4 Deviation from Test Standard 97

5.9.5 Test Setup..... 98

5.9.6 Test Result 99

5.9.7 Photographs of Test Configuration 100



History of this test report

Report No.	Issue date	Description
WD-EE-R-240206-A0	Jul. 17, 2024	Initial Issue

Declaration

This report is for your exclusive use. Any copying or replication of this report to or for any other person or entity, or use of our name or trademark, is permitted only with our prior written permission. This report sets forth our findings solely with respect to the test samples identified herein. The results set forth in this report are not indicative or representative of the quality or characteristics of the lot from which a test sample was taken or any similar or identical product unless specifically and expressly noted. Our report includes all of the tests requested by you and the results thereof based upon the information that you provided to us.



History of supplementary report

Report No.	Issue date	Description
WD-EE-R-240206-A0	Jul. 17, 2024	Original report

Declaration

This report is for your exclusive use. Any copying or replication of this report to or for any other person or entity, or use of our name or trademark, is permitted only with our prior written permission. This report sets forth our findings solely with respect to the test samples identified herein. The results set forth in this report are not indicative or representative of the quality or characteristics of the lot from which a test sample was taken or any similar or identical product unless specifically and expressly noted. Our report includes all of the tests requested by you and the results thereof based upon the information that you provided to us.



1 Certification

Product: Edge AI Computing System
Brand Name: Vecow
Model: EAC-6200
Series Model: EAC-6000 Series, EAC-6XXXXXXXXXXXXXXXXXXXXXXX ("X" can be 0-9, A-Z, - or blank for marketing purpose)
Applicant: Vecow Co., Ltd
Tested: May 31 ~ Jul. 11, 2024
Standard: EN 55032: 2015 + A11: 2020, Class A
BS EN 55032: 2015 + A11: 2020
CISPR 32: 2015
AS/NZS CISPR 32: 2015
EN 61000-3-2: 2014
EN IEC 61000-3-2: 2019 + A1: 2021
EN 61000-3-3: 2013 + A2: 2021
BS EN 61000-3-2: 2014
BS EN IEC 61000-3-2: 2019 + A1: 2021
BS EN 61000-3-3: 2013 + A2: 2021
EN 55035: 2017 + A11: 2020
BS EN 55035: 2017 + A11: 2020
IEC 61000-4-2: 2008
IEC 61000-4-3: 2020
IEC 61000-4-4: 2012
IEC 61000-4-5: 2014 + A1: 2017
IEC 61000-4-6: 2013
IEC 61000-4-8: 2009
IEC 61000-4-11: 2020
EN 61000-4-2: 2009
EN IEC 61000-4-3: 2020
EN 61000-4-4: 2012
EN 61000-4-5: 2014 + A1: 2017
EN 61000-4-6: 2014 + AC: 2015
EN 61000-4-8: 2010
EN IEC 61000-4-11: 2020

The above equipment (Model: EAC-6200) has been tested by **Wendell EMC & RF Laboratory**, and found compliance with the requirement of the above standards. The test record, data evaluation and Equipment Under Test (EUT) configurations represented herein are true and accurate accounts of the measurements of the sample's EMC characteristics under the conditions specified in this report.

Please note that the measurement uncertainty are provided for informational purpose only and are not used in determining the Pass/Fail results.

1.1 Summary of Test Result

The EUT has been tested according to the following specifications:

Emission				
Standard	Test Item	Limit	Result	Remark
EN 55032	Conducted disturbance at mains terminals	Class A	Pass	Meets the requirements
CISPR 32	Conducted disturbance at telecommunication ports test	Class A	Pass	Meets the requirements
	Radiated disturbance	Class A	Pass	Meets the requirements
EN 61000-3-2	Harmonic current emissions	Class A	Pass	The power consumption of EUT is less than 75W and no limits apply
EN 61000-3-3	Voltage fluctuations and flicker	-	Pass	Meets the requirements

Immunity			
Standard	Test Item	Result	Remark
IEC 61000-4-2	Electrostatic discharges (ESD)	Pass	Meets the requirements of Performance Criterion B
IEC 61000-4-3	Continuous radiated disturbances (RS)	Pass	Meets the requirements of Performance Criterion A
IEC 61000-4-4	Electrical fast transients (EFT)	Pass	Meets the requirements of Performance Criterion A
IEC 61000-4-5	Surges	Pass	Meets the requirements of Performance Criterion A
IEC 61000-4-6	Continuous conducted disturbances (CS)	Pass	Meets the requirements of Performance Criterion A
IEC 61000-4-8	Power-frequency magnetic fields (PFMF)	Pass	Meets the requirements of Performance Criterion A
IEC 61000-4-11	Voltage dips and interruptions	Pass	Meets the requirements of Voltage Dips: ✧ >95% reduction – Performance Criterion A ✧ 30% reduction - Performance Criterion A Voltage Interruptions: ✧ >95% reduction – Performance Criterion C

Note: Test record contained in the referenced test report relate only to the EUT sample and test item.

2 Test Configuration of Equipment Under Test

2.1 Test Facility

Conducted disturbance at mains terminals, Conducted disturbance at telecommunication ports, Harmonics, Flicker, ESD, EFT, Surge, CS, PFMF and DIP Tests

W01: 5F-1, No.188, Baoqiao Rd., Xindian Dist., New Taipei City 23145, Taiwan (R.O.C)

RS Test

W05: 1F-7, No.188, Baoqiao Rd., Xindian Dist., New Taipei City 23145, Taiwan (R.O.C)

Conducted disturbance at mains terminals, Conducted disturbance at telecommunication ports and Radiated emission (9*6*6 Chamber) Tests

W08: No.119, Wugong 3rd Rd., Wugu Dist., New Taipei City 248, Taiwan (R.O.C)

ACCREDITATIONS

The laboratories are accredited and approved by the TAF according to ISO/IEC 17025.

2.2 Measurement Uncertainty

The measurement instrumentation uncertainty is evaluated according to CISPR 16-4-2.

This uncertainty represents an expanded uncertainty expressed at approximately the 95% confidence level using a coverage factor of $k=2$.

Wendell EMC & RF Laboratory U_{lab} is less than U_{cispr} , therefore compliance or non-compliance with a disturbance limit shall be determined in the following manner.

- compliance is deemed to occur if no measured disturbance level exceeds the disturbance limit;
- non-compliance is deemed to occur if any measured disturbance level exceeds the disturbance limit.

Please note that the measurement uncertainty (U_{lab}) is provided for informational purpose only and is not used in determining the Pass/Fail results.

2.2.1 Conducted Emission test

Test Site	Measurement Freq. Range	dB (U_{lab})	Note
W01-CE	150 kHz ~ 30 MHz	2.75	N/A
W08-CE	150 kHz ~ 30 MHz	2.76	N/A

2.2.2 Conducted emission at telecom port test

Test Site	Measurement Freq. Range	dB (U_{lab})	Note
W01-CE	150 kHz ~ 30 MHz	2.74	N/A
W08-CE	150 kHz ~ 30 MHz	2.92	N/A

2.2.3 Radiated Emission test

Test Site	Measurement Freq. Range	Ant	dB (U_{lab})	Note
W08-966-1	30 MHz ~ 200 MHz	V	3.78	N/A
	30 MHz ~ 200 MHz	H	2.69	N/A
	200 MHz ~ 1000 MHz	V	4.91	N/A
	200 MHz ~ 1000 MHz	H	3.40	N/A
	1 GHz ~ 6 GHz	V	4.48	N/A
	1 GHz ~ 6 GHz	H	4.33	N/A



3 General Information

3.1 Description of EUT

Product	Edge AI Computing System
Brand	Vecow
Model	EAC-6200
Series Model	EAC-6000 Series, EAC-6XXXXXXXXXXXXXXXXXXXXXXX ("X" can be 0-9, A-Z, - or blank for marketing purpose)
Applicant	Vecow Co., Ltd
Received Date	May 16, 2024
EUT Power Rating	24Vdc (from adapter)
Model Differences	The models are electrically identical, different models no. are for marketing purpose. The series model information is provided by client.
Operating System	Ubuntu 20.04.5 LTS, Burnintest
Data Cable Supplied	N/A
Accessory Device	N/A
I/O Port	Please refer to the User's Manual

Note:

- The EUT uses the follow adapter:

Adapter (support unit only)	
Brand	FSP
Model	FSP120-AAAN2
Input Power	100-240Vac, 1.8A, 50-60Hz
Output Power	24Vdc, 5A
Power line	Input: 1.2m non-shielded cable Output: 1.8m non-shielded cable

- The EUT contains following MB, SSD & GPU board.

Item	Brand	Model	Spec.	Qty.
Main Board	-	EAC-6000	Rev. C	1
M.2 SSDs	Transcend	TS1TMTE712A-I	1TB	1

GPU board:

Item	Spec.
SoM	NVIDIA® Jetson Orin NX 16GB Module
CPU	8-core Cortex-A78AE Armv8.2 (64-bit) CPU
GPU	1024-core Ampere™ GPU with 32 Tensor Cores
RAM	16 GB 128-bit LPDDR5 DRAM

- The EUT's highest operating frequency is 1651MHz. Therefore the radiated emission is tested up to 6GHz.

3.2 Description of Test Modes

Test results are presented in the report as below.

Test Mode	Test Condition
Conducted emission test	
-	Adapter mode
Conducted emission test at telecom port test	
A	Adapter mode, LAN (10Mbps/100Mbps/1Gbps)
B	Adapter mode, PoE (Max)
Radiated emission 30MHz ~ 1GHz test	
-	Adapter mode
Radiated emission above 1GHz test	
-	Adapter mode
Harmonics, Flicker and Immunity test	
-	Adapter mode

3.3 EUT Operating Condition

- Placed the EUT on the test table.
- Prepare PC to act as a communication partner and placed it outside of testing area.
- The EUT was connected to the PC with LAN cable.
- The communication partner sent data to EUT by command "ping" via LAN.
- The IPCAM sent signal to EUT through PoE supply LAN cable.
- The EUT read and write data with Internal SSD & USB flash.
- The EUT run test program "BurnIN.exe" to enable all functions.
- The EUT sent "Color Bar ITU-R.BT471-1" signal to monitor and displayed on screen.



3.4 Description of Support Unit

The EUT has been conducted testing with other necessary accessories or support units.

Item	Equipment	Brand	Model No.	Serial No.	FCC ID	Data Cable	Power Cable	Remark
1	Desktop PC	DELL	D19M	N/A	PPD-QCN FA335	20m CAT.5E non-shielded RJ45 cable	1.8m non-shielded cable	-
2	Desktop PC	DELL	D13M	H6K10 A00	FCC DoC Approved	20m CAT.5E non-shielded RJ45 cable	1.8m non-shielded cable	-
3	4K monitor	HP	HP 27f 4k Display	3CM01935T F	FCC DoC Approved	1.5m shielded HDMI cable with 2 cores	AC: 1.8m non-shielded cable DC: 1.4m non-shielded cable with 1 core	-
4	Keyboard	DELL	KB216t	CN-0W33XP -L0300-7C1- 15UP	FCC DoC Approved	1.5m non-shielded cable	N/A	-
5	Mouse	Logitech	M-U0026	HS726HB	FCC DoC Approved	2m non-shielded cable	N/A	-
6	USB flash	SANDISK	32GB	N/A	FCC DoC Approved	N/A	N/A	-
7	Grounding wire	N/A	N/A	N/A	N/A	1m non-shielded cable	N/A	-
8	CAN bus test device	N/A	N/A	N/A	N/A	0.3m non-shielded CAN bus cable	N/A	Supplied by client
9	IP camera (x4)	Messoa	MBL030A-O RZ0310	N/A	N/A	1m CAT.7 shielded RJ45 cable	N/A	Supplied by client
10	RS232 terminator (x4)	N/A	N/A	N/A	N/A	N/A	N/A	Supplied by client

- Note:**
1. The core(s) is(are) originally attached to the cable(s).
 2. Item 1-2 acted as communication partners to transfer data.

4 Emission Test

4.1 Conducted Emission Measurement

4.1.1 Limit of Conducted Emission Measurement

Class A equipment:

Requirements for conducted emissions from the AC mains power ports of Class A equipment			
Frequency (MHz)	Measurement		Class A limits dB(μ V)
	Coupling device	Detector type/ bandwidth	
0.15 to 0.5	AMN	Quasi Peak / 9 kHz	79
0.5 to 30			73
0.15 to 0.5	AMN	Average / 9 kHz	66
0.5 to 30			60

Class B equipment:

Requirements for conducted emissions from the AC mains power ports of Class B equipment			
Frequency (MHz)	Measurement		Class B limits dB(μ V)
	Coupling device	Detector type/ bandwidth	
0.15 to 0.5	AMN	Quasi Peak / 9 kHz	66 to 56*
0.5 to 5			56
5 to 30			60
0.15 to 0.5	AMN	Average / 9 kHz	56 to 46*
0.5 to 5			46
5 to 30			50

* Decreases with the logarithm of the frequency.

- Note:**
- The lower limit shall apply at the transition frequencies.
 - Detector function in the form: PK = Peak, QP = Quasi Peak, AV = Average
 - The test result calculated as following:
 Measurement Value = Reading Level + Correct Factor
 Correction Factor = Insertion loss of LISN + Cable loss + Transient Limiter (If use)
 Margin Level = Measurement Value – Limit Value



4.1.2 Test Instrument

Test Site: W01-CE					
Item	Equipment	Manufacturer	Model	Meter No.	Calibration Date
1	TWO-LINE V-NETWORK	R&S	ENV216	CT-1-025-1	Jun. 05, 2024
2	Pulse limiter	R&S	ESH3-Z2	CT-2-015	Jun. 06, 2024
3	EMI Test Receiver	R&S	ESCI	CT-1-024	Jun. 06, 2024
4	Artificial Mains Network (AMN)	SCHWARZBECK	NSLK 8127	CT-1-104-1	Jun. 06, 2024
5	RF Cable	MVE	200200.400LL .500A	CT-9-101	Jun. 06, 2024
6	50ohm Termination	N/A	N/A	CT-1-065-1	May 30, 2024
7	Measurement Software	EZ-EMC	Ver: EMC-CON 3A1	CT-3-012	No calibration request

Note: 1. The calibration interval of the above test instruments is 12 months.

Test Site: W08-CE					
Item	Equipment	Manufacturer	Model	Meter No.	Calibration Date
1	TWO-LINE V-NETWORK	R&S	ENV216	CT-1-025-2	Jun. 20, 2024
2	RF Cable	EMCI	EMCCFD300-BM-BM-5000	CT-1-107-2	Jun. 24, 2024
3	EMI Test Receiver	R&S	ESR3	CT-1-103	Jun. 20, 2024
4	Artificial Mains Network (AMN)	SCHWARZBECK	NSLK 8127 RC	CT-1-104-1RC	Jun. 20, 2024
5	Transient Limiter	Electro-Metrics	EM-7600	CT-1-026	Jun. 24, 2024
6	50ohm Termination	N/A	N/A	CT-1-109-1	Jun. 20, 2024
7	Measurement Software	EZ-EMC	Ver: EMC-CON 3A1	CT-3-012	No calibration request

Note: 1. The calibration interval of the above test instruments is 12 months.

4.1.3 Test Procedure

- a. The table-top EUT was placed 0.8 meter height wooden table from the horizontal ground plane with EUT being connected to power source through a line impedance stabilization network (LISN). The floor-standing EUT was placed insulation support unit from the horizontal ground plane. The LISN at least be 80 cm from nearest chassis of EUT.
- b. The line impedance stabilization network (LISN) provides 50 ohm/50uH of coupling impedance for the measuring instrument. All other support equipments powered from additional LISN(s).
- c. Interrelating cables that hang closer than 40 cm to the ground plane shall be folded back and forth in the center forming a bundle. All I/O cables were positioned to simulate typical usage.
- d. All I/O cables that are not connected to a peripheral shall be bundle in the center. The end of the cable may be terminated, if required, using the correct terminating impedance. The overall length shall not exceed 1 m.
- e. The EMI test receiver connected to LISN powering the EUT. The actual test configuration, please refer to EUT test photos.
- f. The receiver scanned from 150kHz to 30MHz for emissions in each of test modes. A scan was taken on both power lines, Line and Neutral, recording at least six highest emissions.
- g. The EUT and cable configuration of the above highest emission levels were recorded. The test data of the worst case was recorded.

4.1.4 Deviation from Test Standard

No deviation



4.1.6 Test Result

Test Voltage	230Vac, 50Hz	Frequency Range	0.15-30 MHz
Environmental Conditions	22°C, 50% RH	6dB Bandwidth	9 kHz
Test Date	2024/07/05	Phase	L
Tested by	Guanwei Liao	Test Site	W01-CE

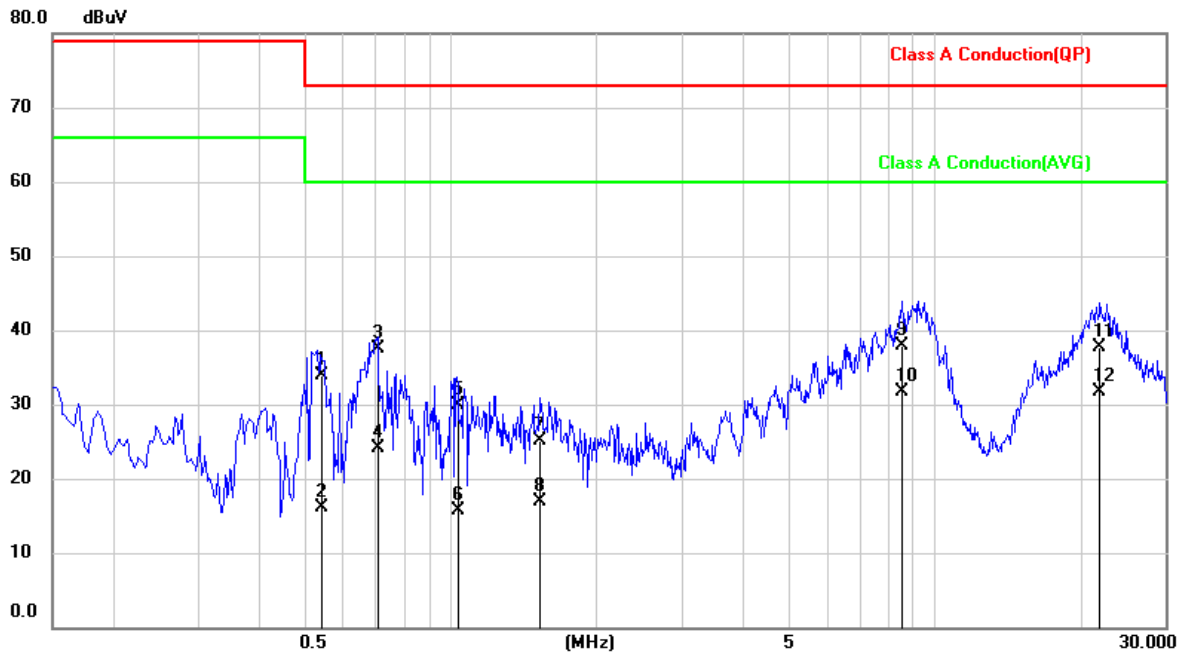

No.	Frequency (MHz)	Reading Level (dBμV)	Correct Factor (dB)	Measurement (dBμV)	Limit (dBμV)	Margin (dB)	Detector
1	0.5418	24.07	9.91	33.98	73.00	-39.02	QP
2	0.5418	6.24	9.91	16.15	60.00	-43.85	AVG
3	0.7049	27.50	9.91	37.41	73.00	-35.59	QP
4	0.7049	14.29	9.91	24.20	60.00	-35.80	AVG
5	1.0354	19.89	9.93	29.82	73.00	-43.18	QP
6	1.0354	5.87	9.93	15.80	60.00	-44.20	AVG
7	1.5265	15.22	9.95	25.17	73.00	-47.83	QP
8	1.5265	6.98	9.95	16.93	60.00	-43.07	AVG
9	8.5451	27.87	10.13	38.00	73.00	-35.00	QP
10	8.5451	21.59	10.13	31.72	60.00	-28.28	AVG
11	21.8927	27.38	10.29	37.67	73.00	-35.33	QP
12	21.8927	21.44	10.29	31.73	60.00	-28.27	AVG

Remark: 1. QP = Quasi Peak, AVG = Average
2. Correction Factor = Insertion loss of LISN + Cable loss + Transient Limiter (If use)
3. Measurement Value = Reading Level + Correct Factor
4. Margin Level = Measurement Value - Limit Value



Test Voltage	230Vac, 50Hz	Frequency Range	0.15-30 MHz
Environmental Conditions	22°C, 50% RH	6dB Bandwidth	9 kHz
Test Date	2024/07/05	Phase	N
Tested by	Guanwei Liao	Test Site	W01-CE

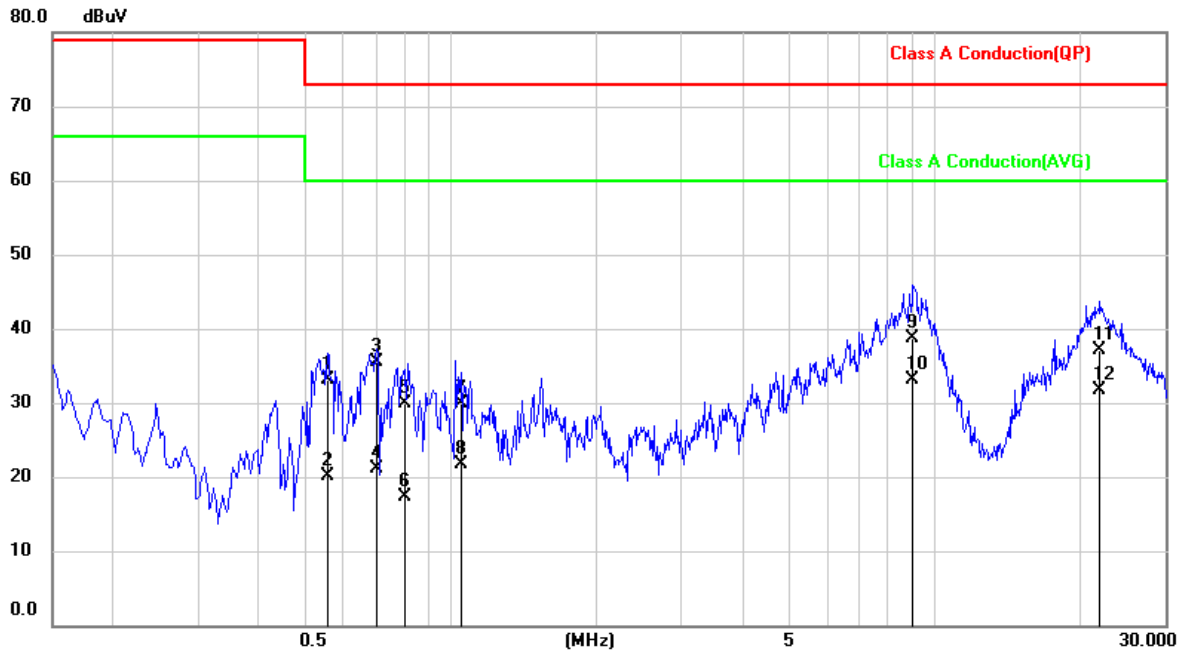

No.	Frequency (MHz)	Reading Level (dBμV)	Correct Factor (dB)	Measurement (dBμV)	Limit (dBμV)	Margin (dB)	Detector
1	0.5540	23.26	9.91	33.17	73.00	-39.83	QP
2	0.5540	10.13	9.91	20.04	60.00	-39.96	AVG
3	0.7002	25.50	9.91	35.41	73.00	-37.59	QP
4	0.7002	11.23	9.91	21.14	60.00	-38.86	AVG
5	0.8064	20.05	9.93	29.98	73.00	-43.02	QP
6	0.8064	7.31	9.93	17.24	60.00	-42.76	AVG
7	1.0467	20.04	9.93	29.97	73.00	-43.03	QP
8	1.0467	11.86	9.93	21.79	60.00	-38.21	AVG
9	8.9749	28.59	10.14	38.73	73.00	-34.27	QP
10	8.9749	22.98	10.14	33.12	60.00	-26.88	AVG
11	21.8923	26.72	10.29	37.01	73.00	-35.99	QP
12	21.8923	21.34	10.29	31.63	60.00	-28.37	AVG

Remark: 1. QP = Quasi Peak, AVG = Average
 2. Correction Factor = Insertion loss of LISN + Cable loss + Transient Limiter (If use)
 3. Measurement Value = Reading Level + Correct Factor
 4. Margin Level = Measurement Value - Limit Value



Test Voltage	110Vac, 60Hz	Frequency Range	0.15-30 MHz
Environmental Conditions	22°C, 50% RH	6dB Bandwidth	9 kHz
Test Date	2024/07/05	Phase	L
Tested by	Guanwei Liao	Test Site	W01-CE

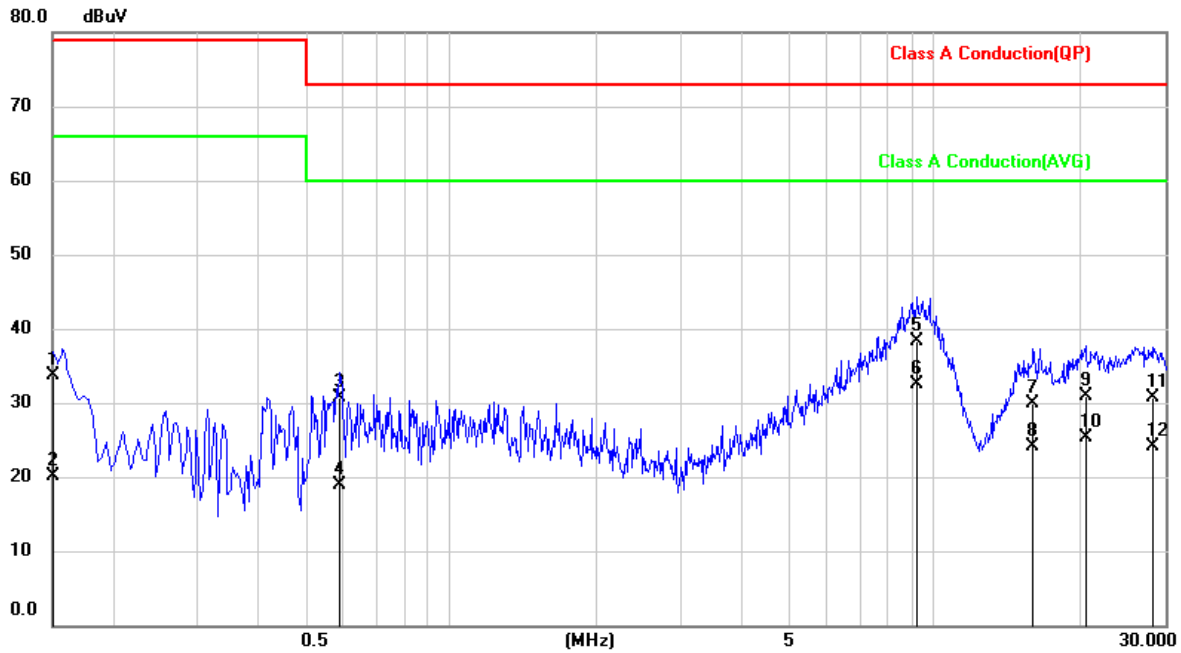

No.	Frequency (MHz)	Reading Level (dBμV)	Correct Factor (dB)	Measurement (dBμV)	Limit (dBμV)	Margin (dB)	Detector
1	0.1500	23.71	9.91	33.62	79.00	-45.38	QP
2	0.1500	10.20	9.91	20.11	66.00	-45.89	AVG
3	0.5874	20.84	9.93	30.77	73.00	-42.23	QP
4	0.5874	8.91	9.93	18.84	60.00	-41.16	AVG
5	9.2064	28.09	10.15	38.24	73.00	-34.76	QP
6	9.2064	22.30	10.15	32.45	60.00	-27.55	AVG
7	16.0126	19.76	10.23	29.99	73.00	-43.01	QP
8	16.0126	13.85	10.23	24.08	60.00	-35.92	AVG
9	20.5474	20.69	10.28	30.97	73.00	-42.03	QP
10	20.5474	15.12	10.28	25.40	60.00	-34.60	AVG
11	28.1852	20.31	10.39	30.70	73.00	-42.30	QP
12	28.1852	13.62	10.39	24.01	60.00	-35.99	AVG

Remark: 1. QP = Quasi Peak, AVG = Average
 2. Correction Factor = Insertion loss of LISN + Cable loss + Transient Limiter (If use)
 3. Measurement Value = Reading Level + Correct Factor
 4. Margin Level = Measurement Value - Limit Value



Test Voltage	110Vac, 60Hz	Frequency Range	0.15-30 MHz
Environmental Conditions	22°C, 50% RH	6dB Bandwidth	9 kHz
Test Date	2024/07/05	Phase	N
Tested by	Guanwei Liao	Test Site	W01-CE

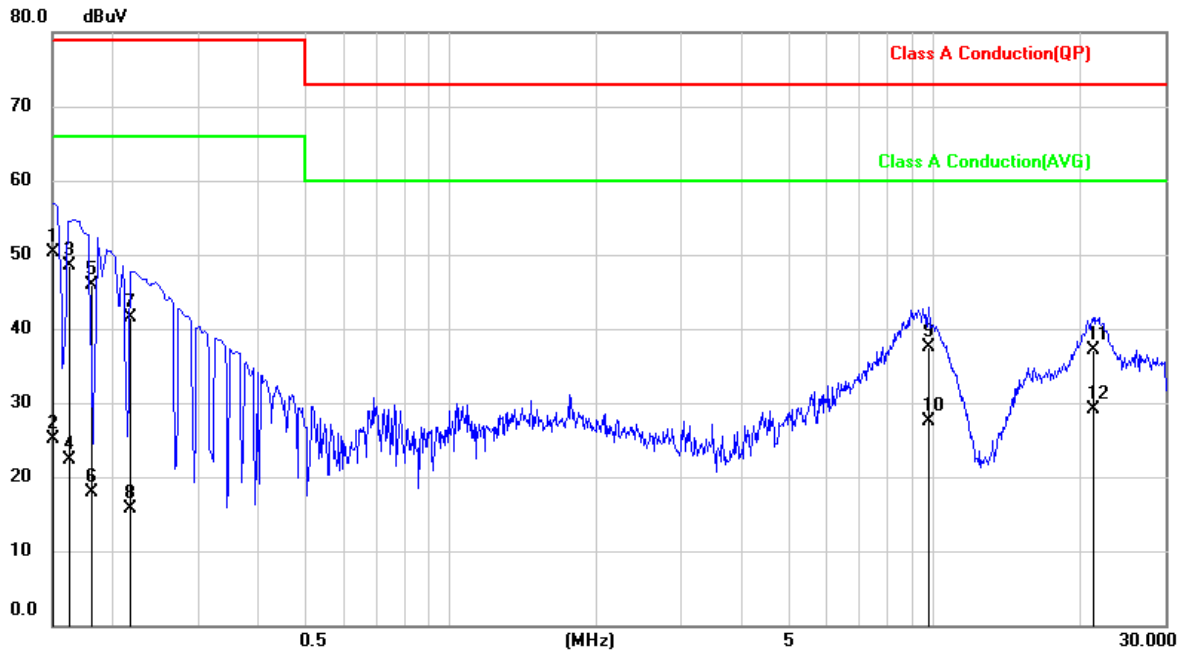

No.	Frequency (MHz)	Reading Level (dBμV)	Correct Factor (dB)	Measurement (dBμV)	Limit (dBμV)	Margin (dB)	Detector
1	0.1505	40.37	9.90	50.27	79.00	-28.73	QP
2	0.1505	15.23	9.90	25.13	66.00	-40.87	AVG
3	0.1621	38.54	9.90	48.44	79.00	-30.56	QP
4	0.1621	12.47	9.90	22.37	66.00	-43.63	AVG
5	0.1818	35.92	9.89	45.81	79.00	-33.19	QP
6	0.1818	8.00	9.89	17.89	66.00	-48.11	AVG
7	0.2178	31.60	9.89	41.49	79.00	-37.51	QP
8	0.2178	5.80	9.89	15.69	66.00	-50.31	AVG
9	9.7384	27.27	10.16	37.43	73.00	-35.57	QP
10	9.7384	17.33	10.16	27.49	60.00	-32.51	AVG
11	21.3038	26.76	10.29	37.05	73.00	-35.95	QP
12	21.3038	18.86	10.29	29.15	60.00	-30.85	AVG

Remark: 1. QP = Quasi Peak, AVG = Average
 2. Correction Factor = Insertion loss of LISN + Cable loss + Transient Limiter (If use)
 3. Measurement Value = Reading Level + Correct Factor
 4. Margin Level = Measurement Value - Limit Value

4.1.7 Photographs of Test Configuration

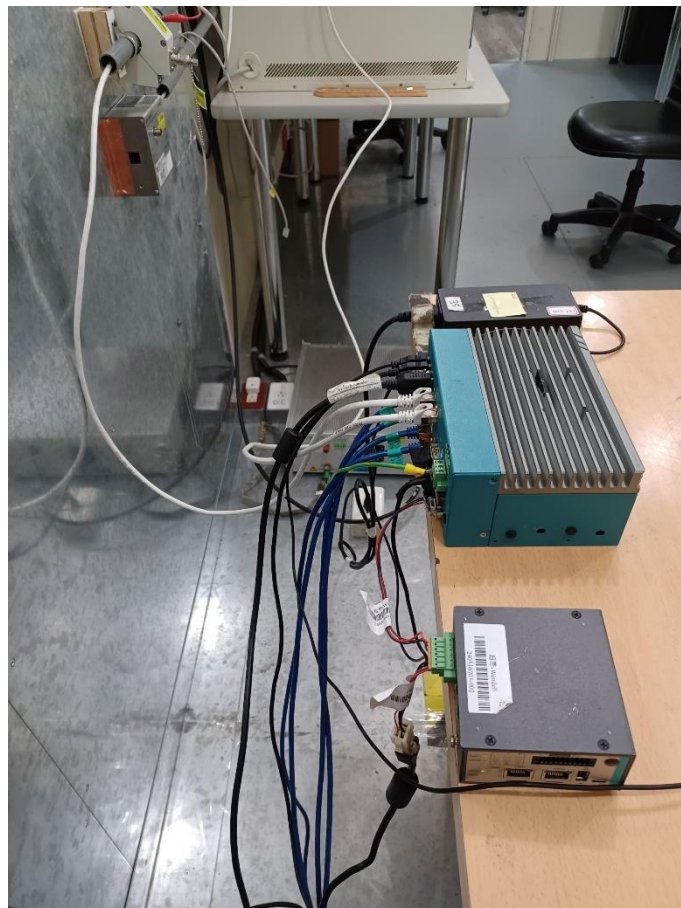

4.2 Conducted Emission at Telecommunication Ports Test

4.2.1 Limit of Conducted Emission at Telecommunication Ports Test

Class A equipment:

Requirements for asymmetric mode conducted emissions from Class A equipment			
Frequency (MHz)	Measurement		Class A limits dB(μ V)
	Coupling device	Detector type/ bandwidth	
0.15 to 0.5	AAN	Quasi Peak / 9 kHz	97 to 87*
0.5 to 30			87
0.15 to 0.5	AAN	Average / 9 kHz	84 to 74*
0.5 to 30			74

* Decreases with the logarithm of the frequency.

Class B equipment:

Requirements for asymmetric mode conducted emissions from Class B equipment			
Frequency (MHz)	Measurement		Class B limits dB(μ V)
	Coupling device	Detector type/ bandwidth	
0.15 to 0.5	AAN	Quasi Peak / 9 kHz	84 to 74*
0.5 to 30			74
0.15 to 0.5	AAN	Average / 9 kHz	74 to 64*
0.5 to 30			64

* Decreases with the logarithm of the frequency.

- Note:**
1. The lower limit shall apply at the transition frequencies.
 2. Detector function in the form: PK = Peak, QP = Quasi Peak, AV = Average
 3. The test result calculated as following:
 Measurement Value = Reading Level + Correct Factor
 Correction Factor = Insertion loss of ISN + Cable loss
 Margin Level = Measurement Value – Limit Value

Class A equipment:

Requirements for asymmetric mode conducted emissions from Class A equipment			
Frequency (MHz)	Measurement		Class A limits dB(μA)
	Coupling device	Detector type/ bandwidth	
0.15 to 0.5	Current Probe	Quasi Peak / 9 kHz	53 to 43*
0.5 to 30			43
0.15 to 0.5	Current Probe	Average / 9 kHz	40 to 30*
0.5 to 30			30

* Decreases with the logarithm of the frequency.

Class B equipment:

Requirements for asymmetric mode conducted emissions from Class B equipment			
Frequency (MHz)	Measurement		Class B limits dB(μA)
	Coupling device	Detector type/ bandwidth	
0.15 to 0.5	Current Probe	Quasi Peak / 9 kHz	40 to 30*
0.5 to 30			30
0.15 to 0.5	Current Probe	Average / 9 kHz	30 to 20*
0.5 to 30			20

* Decreases with the logarithm of the frequency.

- Note:**
1. The lower limit shall apply at the transition frequencies.
 2. Detector function in the form: PK = Peak, QP = Quasi Peak, AV = Average
 3. The test result calculated as following:
 Measurement Value = Reading Level + Correct Factor
 Correction Factor = Insertion loss of Current Probe + Cable loss
 Margin Level = Measurement Value – Limit Value



4.2.2 Test Instrument

Test Site: W01-CE					
Item	Equipment	Manufacturer	Model	Meter No.	Calibration Date
1	TWO-LINE V-NETWORK	R&S	ENV216	CT-1-025-1	Jun. 05, 2024
2	EMI Test Receiver	R&S	ESCI	CT-1-024	Jun. 06, 2024
3	Impedance Stabilization Network	TESEQ	T8-CAT6	CT-1-105	Jun. 12, 2024
4	Artificial Mains Network (AMN)	SCHWARZBECK	NSLK 8127	CT-1-104-1	Jun. 06, 2024
5	RF Cable	MVE	200200.400LL .500A	CT-9-101	Jun. 06, 2024
6	50ohm Termination	N/A	N/A	CT-1-065-2	Jun. 06, 2024
7	Measurement Software	EZ-EMC	Ver: EMC-CON 3A1	CT-3-012	No calibration request
8	Current Probe	TESEQ	CSP 9160A	CT-1-106	Jun. 12, 2023

- Note:** 1. The calibration interval of test instruments is 12 months.
2. The calibration interval of Current Probe is 24 months.

Test Site: W08-CE					
Item	Equipment	Manufacturer	Model	Meter No.	Calibration Date
1	TWO-LINE V-NETWORK	R&S	ENV216	CT-1-025-2	Jun. 20, 2024
2	RF Cable	EMCI	EMCCFD300-BM-BM-5000	CT-1-107-2	Jun. 24, 2024
3	EMI Test Receiver	R&S	ESR3	CT-1-103	Jun. 20, 2024
4	Artificial Mains Network (AMN)	SCHWARZBECK	NSLK 8127 RC	CT-1-104-1R C	Jun. 20, 2024
5	Four Balanced Pair ISN	FCC	F-071115-105 7-1-09	CT-1-027	Jun. 24, 2024
6	50ohm Termination	N/A	N/A	CT-1-109-2	Jun. 20, 2024
7	Measurement Software	EZ-EMC	Ver: EMC-CON 3A1	CT-3-012	No calibration request

- Note:** 1. The calibration interval of the above test instruments is 12 months.

4.2.3 Test Procedure

- a. The table-top EUT was placed 0.8 meter height wooden table from the horizontal ground plane with EUT being connected to power source through a line impedance stabilization network (LISN). The floor-standing EUT was placed insulation support unit from the horizontal ground plane. The LISN at least be 80 cm from nearest chassis of EUT.
- b. The line impedance stabilization network (LISN) provides 50 ohm/50uH of coupling impedance for the measuring instrument. All other support equipments powered from additional LISN(s).
- c. Interrelating cables that hang closer than 40 cm to the ground plane shall be folded back and forth in the center forming a bundle. All I/O cables were positioned to simulate typical usage.
- d. All I/O cables that are not connected to a peripheral shall be bundle in the center. The end of the cable may be terminated, if required, using the correct terminating impedance. The overall length shall not exceed 1 m.
- e. The current probe to EUT horizontal distance may be increased to 0.8 m. Break the external protective insulation (exposing the shield) and connect a 150 Ω resistor with a physical connection between the cable screen and the RGP. The 150 Ω resistor shall be ≤ 0.3 m from the outside surface of the screen to ground. The communication function of EUT was executed in normal condition. The actual test configuration, please refer to EUT test photos.
- f. The receiver scanned from 150kHz to 30MHz for emissions in each of test modes. The test mode included 10Mbps, 100Mbps, 1Gbps, 10Gbps and POE mode. Emission frequency and amplitude were recorded, recording at least six highest emissions.
- g. The EUT and cable configuration of the above highest emission levels were recorded. The test data of the worst case was recorded.

4.2.4 Deviation from Test Standard

No deviation



4.2.6 Test Result

Test Voltage	230Vac, 50Hz	Frequency Range	0.15-30 MHz
Environmental Conditions	22°C, 50% RH	6dB Bandwidth	9 kHz
Test Date	2024/07/05	Test Condition	LAN port (10Mbps)
Tested by	Guanwei Liao	Test Site	W01-CE
Test Mode	A		

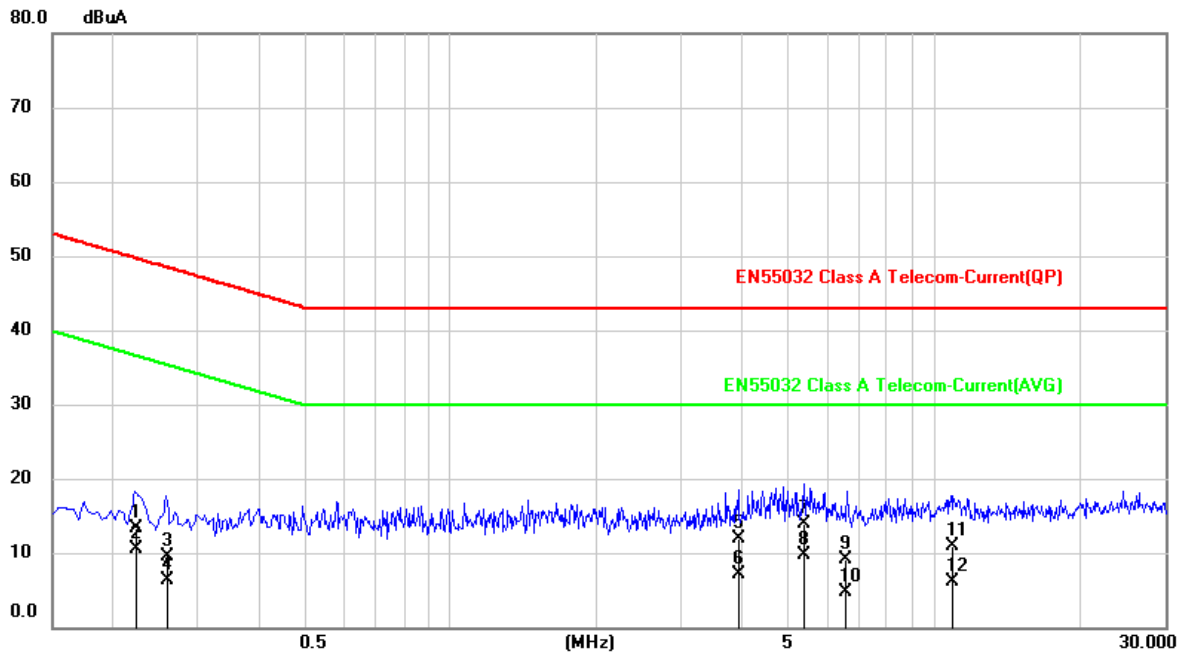

No.	Frequency (MHz)	Reading Level (dBµA)	Correct Factor (dB)	Measurement (dBµA)	Limit (dBµA)	Margin (dB)	Detector
1	0.2236	2.97	10.38	13.35	49.68	-36.33	QP
2	0.2236	0.07	10.38	10.45	36.68	-26.23	AVG
3	0.2592	-0.84	10.36	9.52	48.46	-38.94	QP
4	0.2592	-4.08	10.36	6.28	35.46	-29.18	AVG
5	3.9368	1.54	10.42	11.96	43.00	-31.04	QP
6	3.9368	-3.26	10.42	7.16	30.00	-22.84	AVG
7	5.3734	3.52	10.40	13.92	43.00	-29.08	QP
8	5.3734	-0.71	10.40	9.69	30.00	-20.31	AVG
9	6.5620	-0.99	10.19	9.20	43.00	-33.80	QP
10	6.5620	-5.51	10.19	4.68	30.00	-25.32	AVG
11	10.8634	0.45	10.42	10.87	43.00	-32.13	QP
12	10.8634	-4.27	10.42	6.15	30.00	-23.85	AVG

Remark: 1. QP = Quasi Peak, AVG = Average
 2. Correction Factor = Insertion loss of Current Probe + Cable loss
 3. Measurement Value = Reading Level + Correct Factor
 4. Margin Level = Measurement Value - Limit Value



Test Voltage	230Vac, 50Hz	Frequency Range	0.15-30 MHz
Environmental Conditions	22°C, 50% RH	6dB Bandwidth	9 kHz
Test Date	2024/07/05	Test Condition	LAN port (100Mbps)
Tested by	Guanwei Liao	Test Site	W01-CE
Test Mode	A		

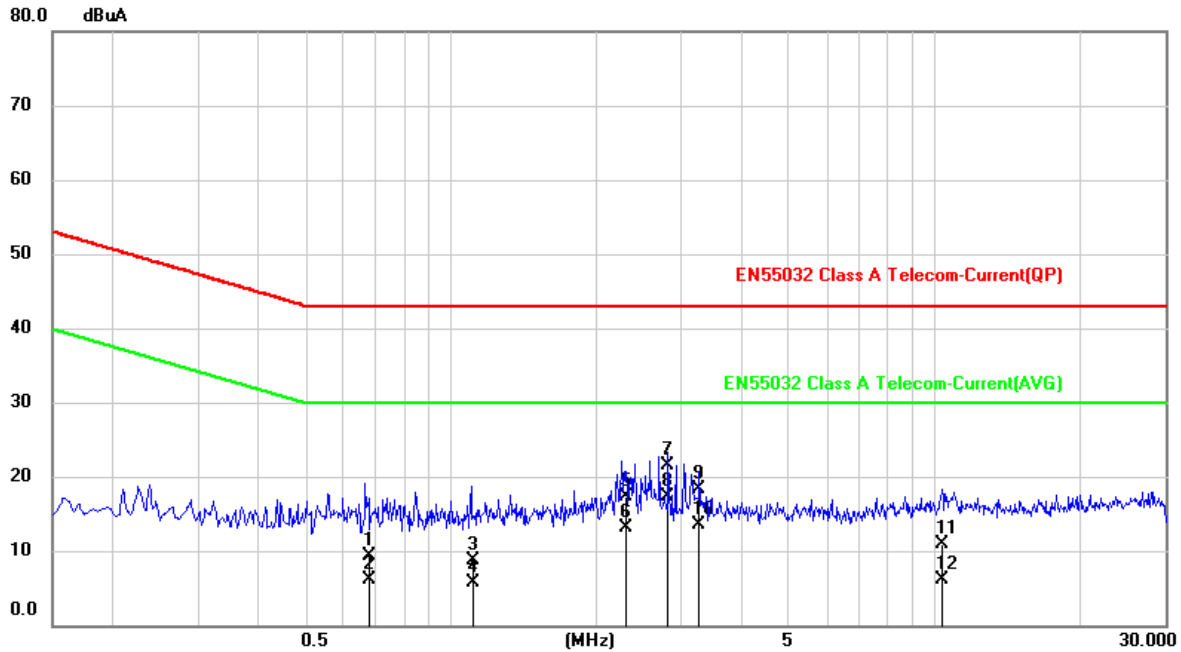

No.	Frequency (MHz)	Reading Level (dBμA)	Correct Factor (dB)	Measurement (dBμA)	Limit (dBμA)	Margin (dB)	Detector
1	0.6803	-1.08	10.32	9.24	43.00	-33.76	QP
2	0.6803	-4.13	10.32	6.19	30.00	-23.81	AVG
3	1.1174	-1.68	10.33	8.65	43.00	-34.35	QP
4	1.1174	-4.68	10.33	5.65	30.00	-24.35	AVG
5	2.3065	6.95	10.37	17.32	43.00	-25.68	QP
6	2.3065	2.67	10.37	13.04	30.00	-16.96	AVG
7	2.8131	11.12	10.39	21.51	43.00	-21.49	QP
8	2.8131	6.95	10.39	17.34	30.00	-12.66	AVG
9	3.2644	7.87	10.40	18.27	43.00	-24.73	QP
10	3.2644	3.10	10.40	13.50	30.00	-16.50	AVG
11	10.3836	0.48	10.42	10.90	43.00	-32.10	QP
12	10.3836	-4.26	10.42	6.16	30.00	-23.84	AVG

Remark: 1. QP = Quasi Peak, AVG = Average
 2. Correction Factor = Insertion loss of Current Probe + Cable loss
 3. Measurement Value = Reading Level + Correct Factor
 4. Margin Level = Measurement Value - Limit Value



Test Voltage	230Vac, 50Hz	Frequency Range	0.15-30 MHz
Environmental Conditions	22°C, 50% RH	6dB Bandwidth	9 kHz
Test Date	2024/07/05	Test Condition	LAN port (1Gbps)
Tested by	Guanwei Liao	Test Site	W01-CE
Test Mode	A		

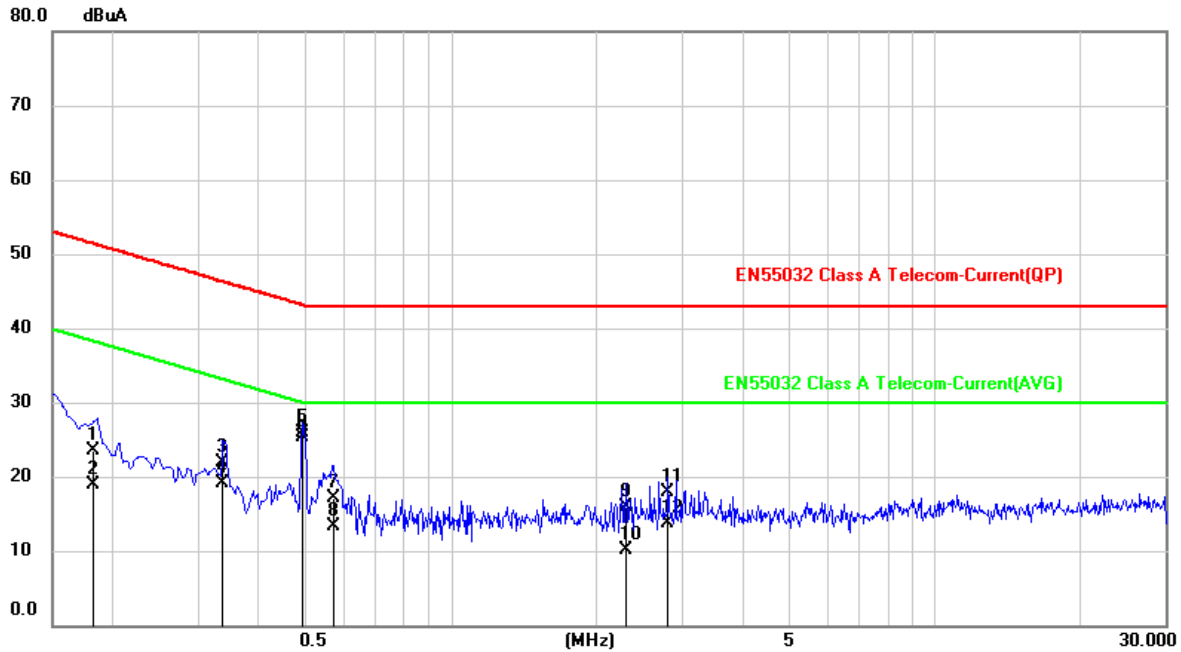

No.	Frequency (MHz)	Reading Level (dBμA)	Correct Factor (dB)	Measurement (dBμA)	Limit (dBμA)	Margin (dB)	Detector
1	0.1815	13.08	10.46	23.54	51.42	-27.88	QP
2	0.1815	8.47	10.46	18.93	38.42	-19.49	AVG
3	0.3387	11.59	10.33	21.92	46.24	-24.32	QP
4	0.3387	8.86	10.33	19.19	33.24	-14.05	AVG
5	0.4940	15.56	10.32	25.88	43.10	-17.22	QP
6	0.4940	15.01	10.32	25.33	30.10	-4.77	AVG
7	0.5752	6.81	10.32	17.13	43.00	-25.87	QP
8	0.5752	3.01	10.32	13.33	30.00	-16.67	AVG
9	2.3046	5.60	10.37	15.97	43.00	-27.03	QP
10	2.3046	-0.17	10.37	10.20	30.00	-19.80	AVG
11	2.8136	7.58	10.39	17.97	43.00	-25.03	QP
12	2.8136	3.40	10.39	13.79	30.00	-16.21	AVG

Remark:

1. QP = Quasi Peak, AVG = Average
2. Correction Factor = Insertion loss of Current Probe + Cable loss
3. Measurement Value = Reading Level + Correct Factor
4. Margin Level = Measurement Value - Limit Value



Test Voltage	230Vac, 50Hz	Frequency Range	0.15-30 MHz
Environmental Conditions	22°C, 50% RH	6dB Bandwidth	9 kHz
Test Date	2024/07/05	Test Condition	PoE port (Max)
Tested by	Guanwei Liao	Test Site	W01-CE
Test Mode	B		

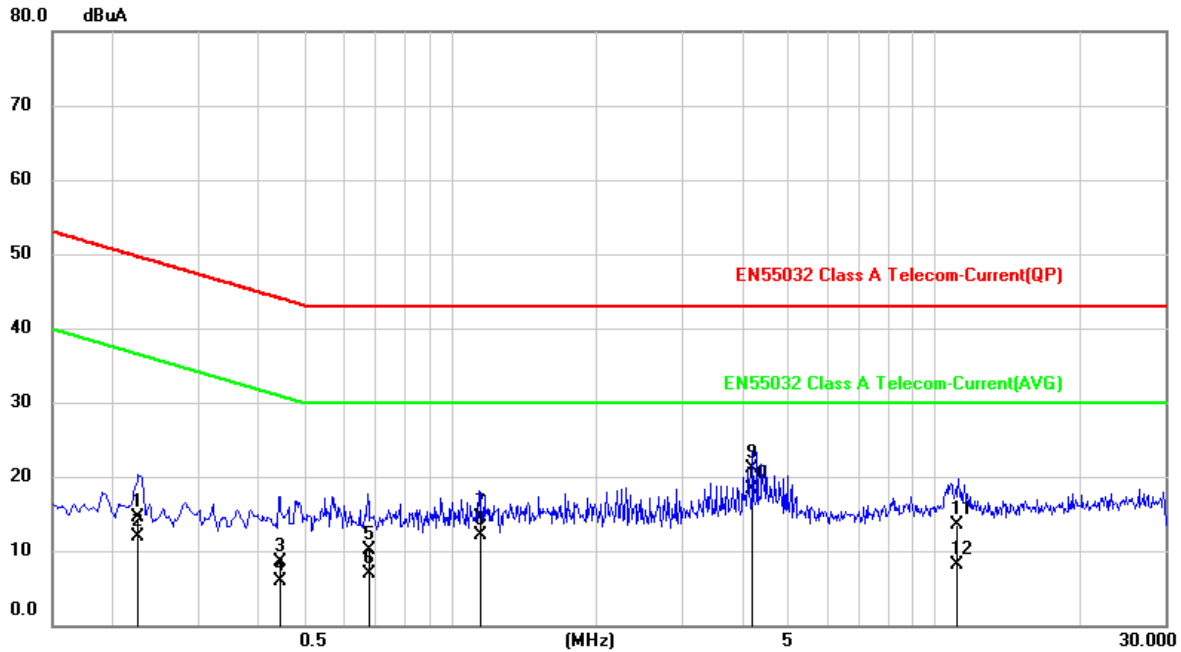

No.	Frequency (MHz)	Reading Level (dBµA)	Correct Factor (dB)	Measurement (dBµA)	Limit (dBµA)	Margin (dB)	Detector
1	0.2257	4.19	10.38	14.57	49.61	-35.04	QP
2	0.2257	1.56	10.38	11.94	36.61	-24.67	AVG
3	0.4431	-1.78	10.33	8.55	44.00	-35.45	QP
4	0.4431	-4.48	10.33	5.85	31.00	-25.15	AVG
5	0.6782	-0.28	10.32	10.04	43.00	-32.96	QP
6	0.6782	-3.39	10.32	6.93	30.00	-23.07	AVG
7	1.1490	4.12	10.33	14.45	43.00	-28.55	QP
8	1.1490	1.74	10.33	12.07	30.00	-17.93	AVG
9	4.2101	10.66	10.42	21.08	43.00	-21.92	QP
10	4.2101	7.90	10.42	18.32	30.00	-11.68	AVG
11	11.1385	3.06	10.42	13.48	43.00	-29.52	QP
12	11.1385	-2.27	10.42	8.15	30.00	-21.85	AVG

Remark: 1. QP = Quasi Peak, AVG = Average
 2. Correction Factor = Insertion loss of Current Probe + Cable loss
 3. Measurement Value = Reading Level + Correct Factor
 4. Margin Level = Measurement Value - Limit Value

4.2.7 Photographs of Test Configuration

Test mode A



Test mode B

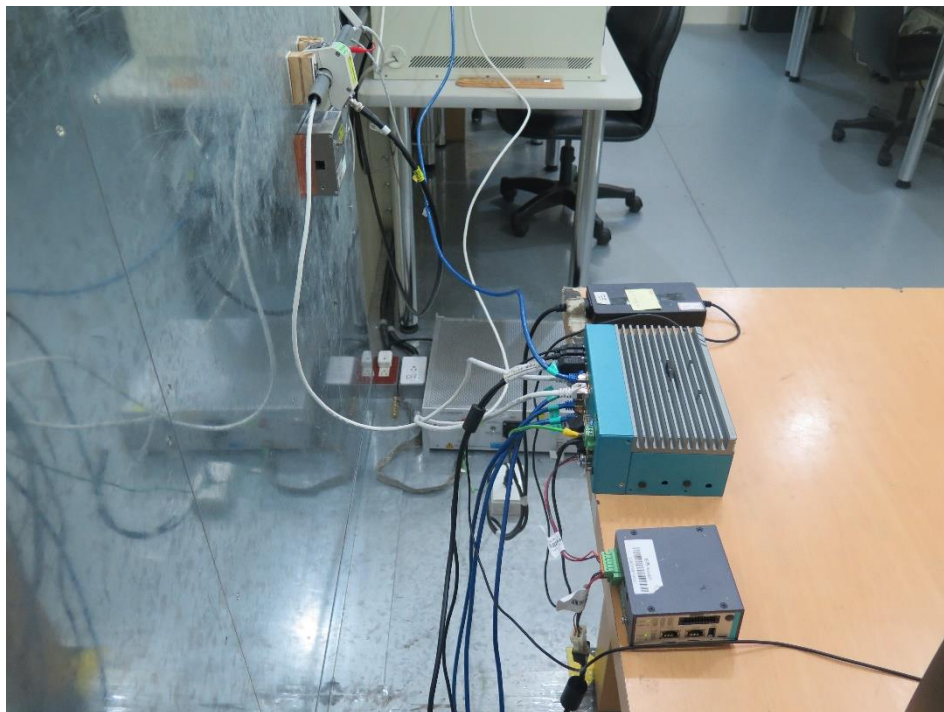
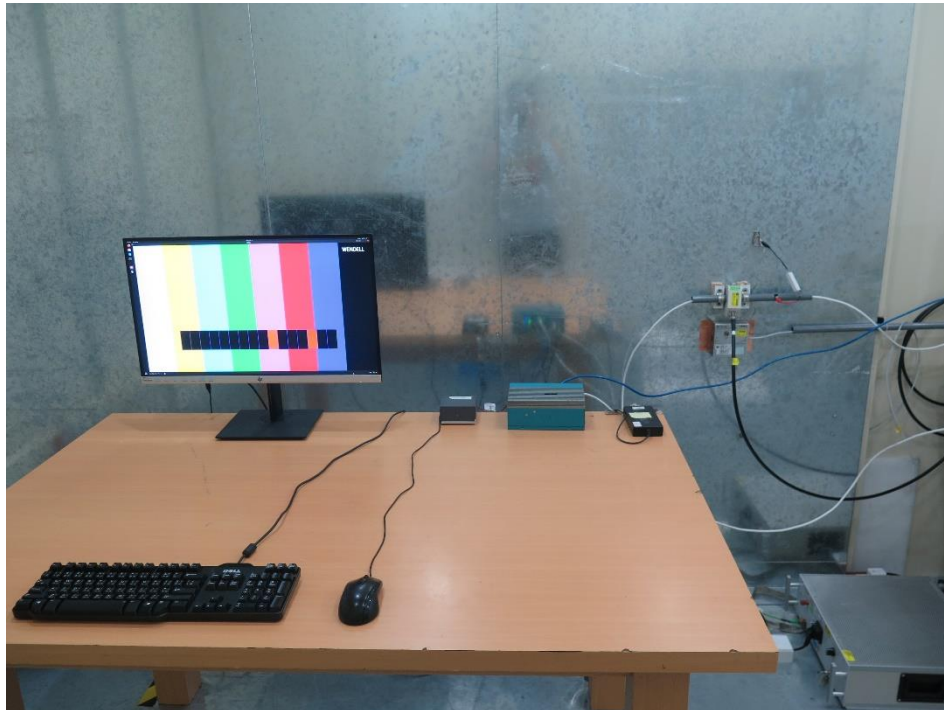

4.3 Radiated Emission Measurement

4.3.1 Limits of Radiated Emission Measurement

According to EN 55032 table1 - Required highest frequency for radiated measurement:

Highest internal frequency (F_x)	Highest measured frequency
$F_x \leq 108$ MHz	1 GHz
$108 \text{ MHz} < F_x \leq 500$ MHz	2 GHz
$500 \text{ MHz} < F_x \leq 1$ GHz	5 GHz
$F_x > 1$ GHz	$5 \times F_x$ up to a maximum of 6 GHz

Remark:

1. F_x : highest fundamental frequency generated or used within the EUT or highest frequency at which it operates.
2. Where F_x is unknown, the radiated emission measurements shall be performed up to 6 GHz.

Class A equipment:

Requirements for radiated emissions at frequencies up to 1 GHz for Class A equipment			
Frequency (MHz)	Measurement		Class A limits dB(μ V/m)
	Distance (m)	Detector type/ bandwidth	OATS/SAC
30 to 230	10	Quasi Peak / 120 kHz	40
230 to 1000			47
30 to 230	3		50
230 to 1000			57

Requirements for radiated emissions at frequencies above 1 GHz for Class A equipment			
Frequency (MHz)	Measurement		Class A limits dB(μ V/m)
	Distance (m)	Detector type/ bandwidth	FSOATS
1000 to 3000	3	Average / 1 MHz	56
3000 to 6000			60
1000 to 3000		Peak / 1 MHz	76
3000 to 6000			80



Class B equipment:

Requirements for radiated emissions at frequencies up to 1 GHz for Class B equipment			
Frequency (MHz)	Measurement		Class B limits dB(μ V/m)
	Distance (m)	Detector type/ bandwidth	OATS/SAC
30 to 230	10	Quasi Peak / 120 kHz	30
230 to 1000			37
30 to 230	3		40
230 to 1000			47

Requirements for radiated emissions at frequencies above 1 GHz for Class B equipment			
Frequency (MHz)	Measurement		Class B limits dB(μ V/m)
	Distance (m)	Detector type/ bandwidth	FSOATS
1000 to 3000	3	Average / 1 MHz	50
3000 to 6000			54
1000 to 3000		Peak / 1 MHz	70
3000 to 6000			74

- Note:**
- The lower limit shall apply at the transition frequency.
 - Detector function in the form: PK = Peak, QP = Quasi Peak, AV = Average
 - The test result calculated as following:
 Measurement Value = Reading Level + Correct Factor
 Correction Factor = Antenna factor + Cable loss (Antenna to preamplifier) - preamplifier Gain
 + Cable loss (preamplifier to receiver)
 Margin Level = Measurement Value - Limit Value



4.3.2 Test Instrument

Test Site: W08-966-1					
Item	Equipment	Manufacturer	Model	Meter No.	Calibration Date
1	Horn Antenna	Schwarzbeck	BBHA 9120D	CT-9-031	Jul. 31, 2023
2	Horn Antenna	Schwarzbeck	BBHA 9170	CT-9-032	Aug. 21, 2023
3	TRILOG Broadband Antenna with 6 dB Attenuator	Schwarzbeck & MVE	VULB 9168 & MVE2251-06	CT-1-096-1	May 06, 2024
4	Spectrum Analyzer	Agilent	E4407B	CT-1-003(1)	Aug. 02, 2023
5	EXA Signal Analyzer	Keysight	N9010A	CT-1-093	Aug. 18, 2023
6	EMI Test Receiver	Keysight	N9038A	CT-9-007	Aug. 02, 2023
7	Preamplifier	EM	EM 330	CT-9-024	Aug. 03, 2023
8	Preamplifier	SGH & MCL	SGH118 & BW-S15W2+	CT-9-071	Aug. 03, 2023
9	Preamplifier	EMCI	EMC184045SE	CT-9-013	Aug. 22, 2023
10	Test Cable	EMCI	EMCCFD400-NM-NM-1000	CT-1-132	Aug. 03, 2023
11	Test Cable	PEWC	CFD400NL-LW-NM-NM-3000	CT-1-141	Aug. 03, 2023
12	Test Cable	EMCI	EMCCFD400-NM-NM-15000	CT-1-133	Aug. 03, 2023
13	Test Cable	EMCI	EMC104-SM-35M-600	CT-1-134	Aug. 03, 2023
14	Test Cable	MVE	280280.LL266.1400	CT-9-072	Aug. 03, 2023
15	Test Cable	EMCI	EMC102-KM-KM-600	CT-1-136	Aug. 22, 2023
16	Measurement Software	EZ-EMC	Ver :WD-03A1-1	CT-3-012	No calibration request

Note: 1. The calibration interval of the above test instruments is 12 months.

4.3.3 Test Procedure

- a. The table-top EUT was placed on the top of a turntable 0.8 meters above the ground at 3 m 966 chamber. The floor-standing EUT was placed insulation support unit from the horizontal ground plane. The table was rotated 360 degrees to determine the position of the high radiation emissions.
- b. The height of the test antenna shall vary between 1 m to 4 m. Both vertical and horizontal polarizations of the antenna were set to make the measurement.
- c. The EUT was set up as per the test configuration to simulate typical usage per the user's manual. All I/O cables were positioned to simulate typical usage. The actual test configuration, please refer to EUT test photos.
- d. The initial step in collecting radiated emission data is a Spectrum Mode scanning the measurement frequency range.

Below 1GHz:

Reading in which marked as QP or Peak means measurements by using Spectrum Mode with detector RBW=120kHz.

If the Spectrum Mode measured peak value compliance with and lower than Quasi Peak Limit, the EUT shall be deemed to meet QP Limits.

Above 1GHz:

Reading in which marked as Peak & AVG means measurements by using Spectrum Mode with setting in RBW=1MHz.

If the Spectrum Mode measured value compliance with the Peak Limits and lower than AVG Limits, the EUT shall be deemed to meet both Peak and AVG Limits.

- e. Emission frequency and amplitude were recorded, recording at least six highest emissions. The EUT and cable configuration of the above highest emission levels were recorded. The test data of the worst case was recorded.

4.3.4 Deviation from Test Standard

No deviation

4.3.5 Test Setup

< Radiated Emissions Frequency: 30 MHz to 1000 MHz >

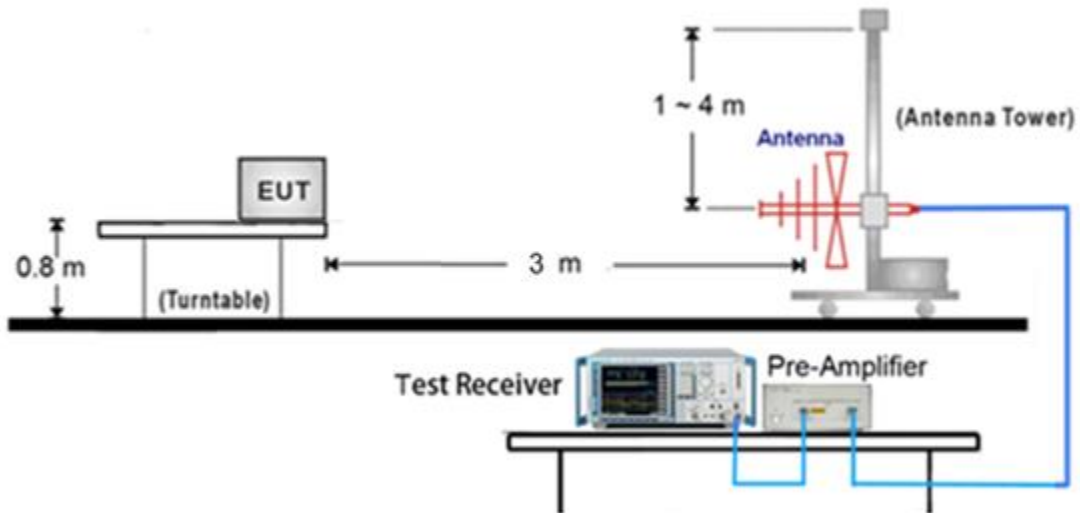

< Radiated Emissions Frequency: above 1GHz >

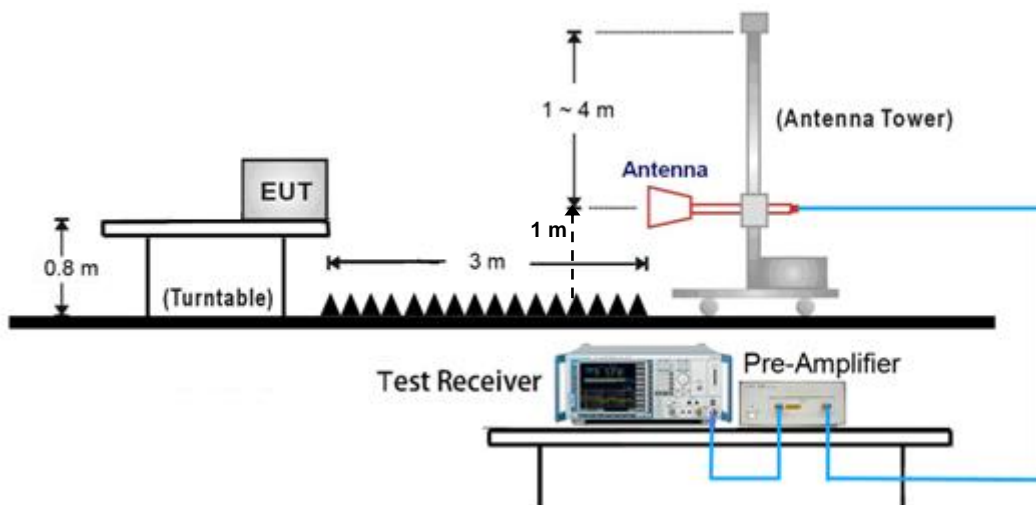

Note:

- (1) Please refer to the 4.3.7 for the actual test configuration.
- (2) The formula of measured value as: $\text{Test Result} = \text{Reading} + \text{Correction Factor}$
- (3) Detector function in the form: PK = Peak, QP = Quasi Peak, AV = Average
- (4) The test result calculated as following:
 $\text{Measurement Value} = \text{Reading Level} + \text{Correct Factor}$
 $\text{Correct Factor} = \text{Antenna Factor} + \text{Cable Loss} - \text{Amplifier Gain (if use)}$
 $\text{Margin Level} = \text{Measurement Value} - \text{Limit Value}$

< EUT placement top view and measurement distance >

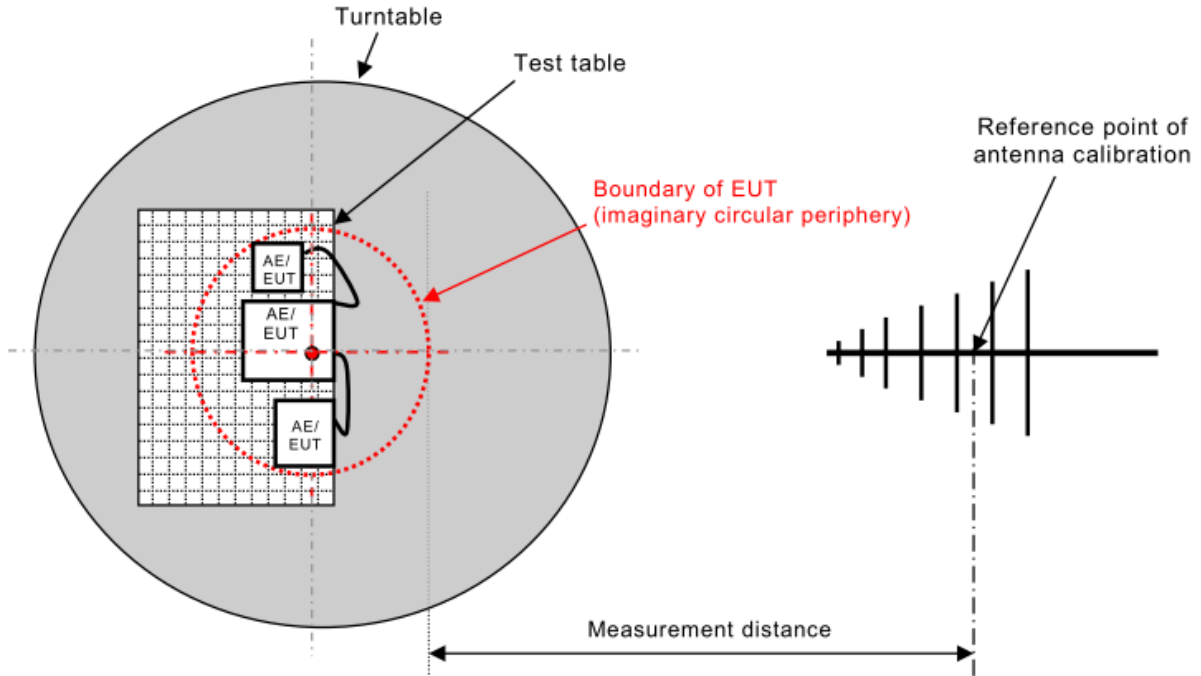

< Boundary of EUT, Local AE and associated cabling >

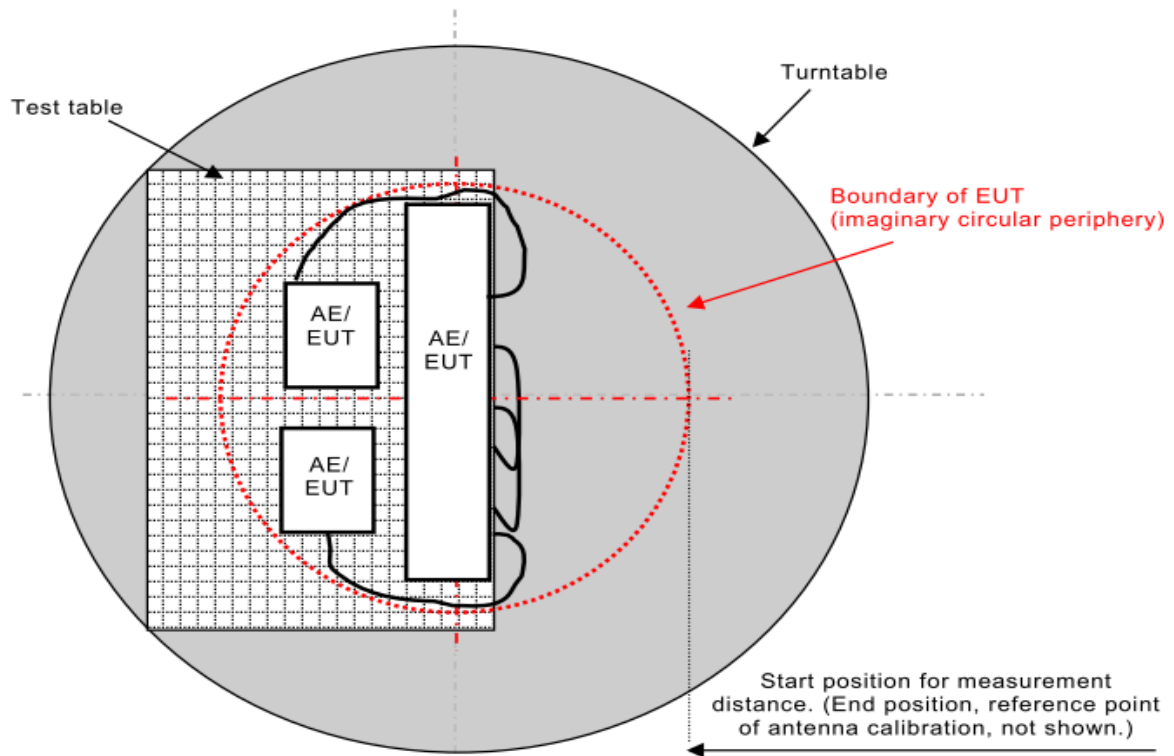

< Table-Top equipment >

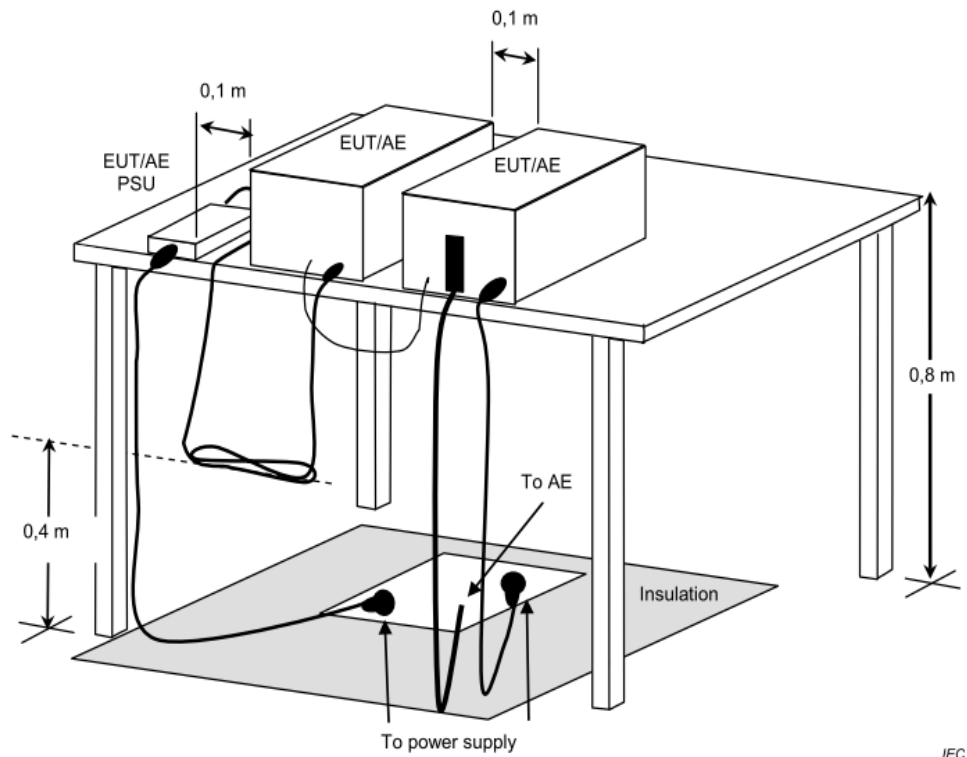

< Floor-Standing equipment >

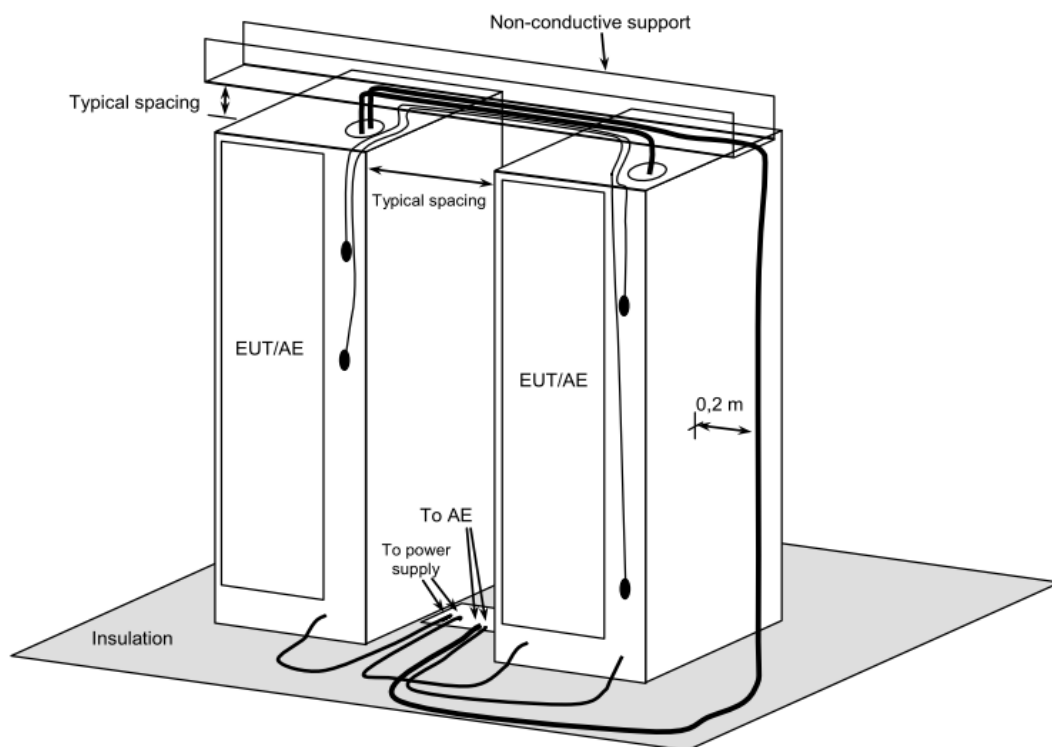

Note: Please refer to the 4.3.7 for the actual test configuration.



4.3.6 Test Result

Test Voltage	230Vac, 50Hz	Frequency Range	30 – 1000 MHz
Environmental Conditions	27°C, 55% RH	6dB Bandwidth	120 kHz
Test Date	2024/07/08	Test Distance	3m
Tested by	Karwin Kao	Polarization	Vertical
Test Site	W08-966-1		

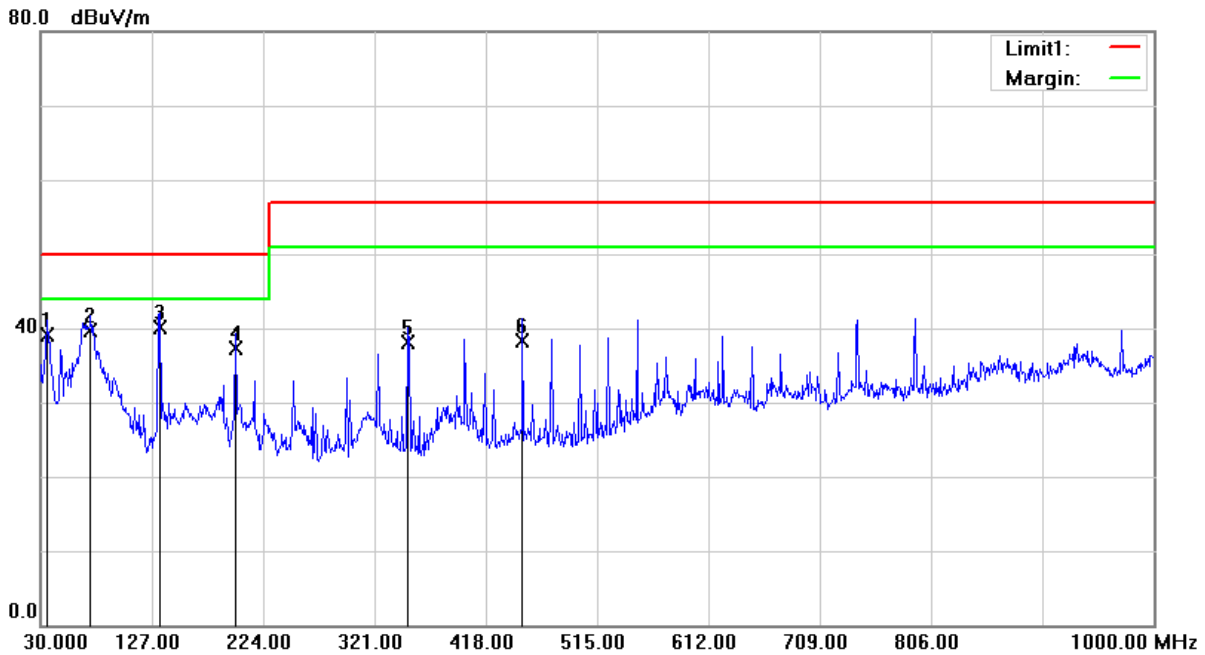

No.	Frequency (MHz)	Reading Level (dBμV)	Correct Factor (dB/m)	Measurement (dBμV/m)	Limit (dBμV/m)	Margin (dB)	Table Degree (degree)	Antenna Height (cm)	Detector
1	35.8200	50.28	-11.16	39.12	50.00	-10.88	209	100	QP
2	73.6500	52.47	-12.81	39.66	50.00	-10.34	195	100	QP
3	133.7900	50.74	-10.73	40.01	50.00	-9.99	74	100	QP
4	199.7500	49.84	-12.59	37.25	50.00	-12.75	155	100	QP
5	350.1000	45.40	-7.30	38.10	57.00	-18.90	172	200	QP
6	450.0100	42.27	-3.97	38.30	57.00	-18.70	311	100	QP

Remark: 1. QP = Quasi Peak
 2. Correction Factor = Antenna factor + Cable loss (Antenna to preamplifier) - preamplifier Gain + Cable loss (preamplifier to receiver)
 3. Measurement Value = Reading Level + Correct Factor
 4. Margin Level = Measurement Value - Limit Value



Test Voltage	230Vac, 50Hz	Frequency Range	30 – 1000 MHz
Environmental Conditions	27°C, 55% RH	6dB Bandwidth	120 kHz
Test Date	2024/07/08	Test Distance	3m
Tested by	Karwin Kao	Polarization	Horizontal
Test Site	W08-966-1		

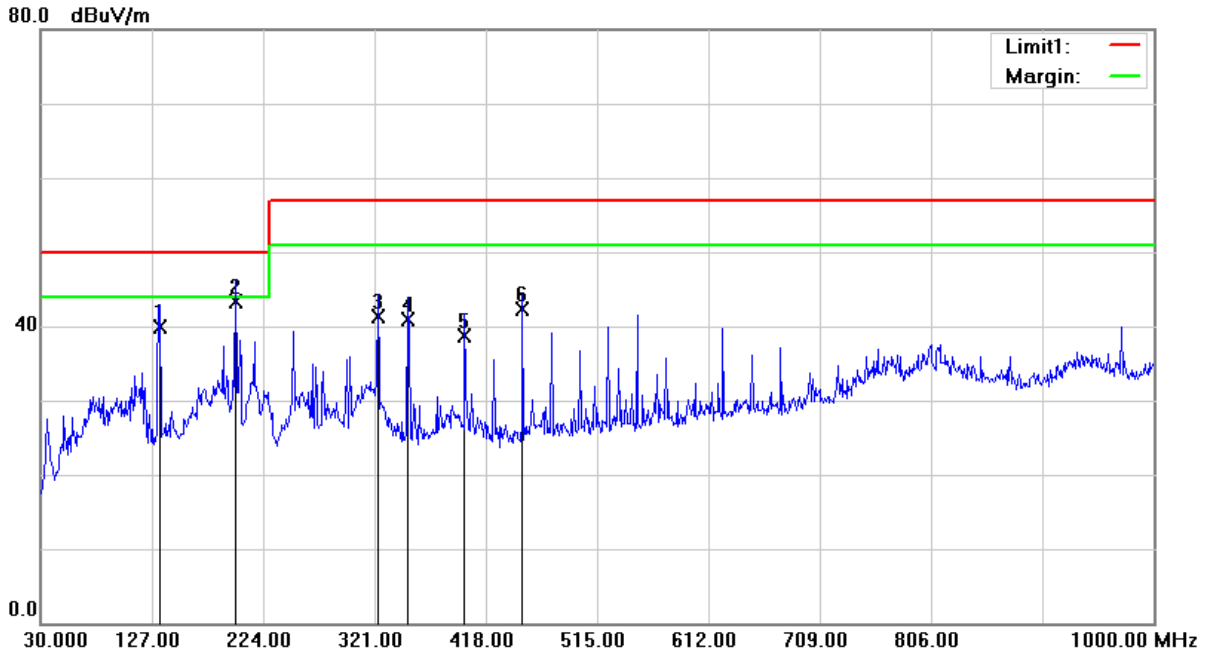

No.	Frequency (MHz)	Reading Level (dBμV)	Correct Factor (dB/m)	Measurement (dBμV/m)	Limit (dBμV/m)	Margin (dB)	Table Degree (degree)	Antenna Height (cm)	Detector
1	133.7900	50.68	-10.73	39.95	50.00	-10.05	265	200	QP
2	199.7500	55.80	-12.59	43.21	50.00	-6.79	333	200	QP
3	323.9100	49.00	-7.74	41.26	57.00	-15.74	293	100	QP
4	350.1000	48.12	-7.30	40.82	57.00	-16.18	276	100	QP
5	399.5700	44.50	-5.77	38.73	57.00	-18.27	219	100	QP
6	450.0100	46.23	-3.97	42.26	57.00	-14.74	80	100	QP

Remark: 1. QP = Quasi Peak
 2. Correction Factor = Antenna factor + Cable loss (Antenna to preamplifier) - preamplifier Gain + Cable loss (preamplifier to receiver)
 3. Measurement Value = Reading Level + Correct Factor
 4. Margin Level = Measurement Value - Limit Value



Test Voltage	230Vac, 50Hz	Frequency Range	1 – 6GHz
Environmental Conditions	27°C, 55% RH	6dB Bandwidth	1MHz
Test Date	2024/07/08	Test Distance	3m
Tested by	Karwin Kao	Polarization	Vertical
Test Site	W08-966-1		

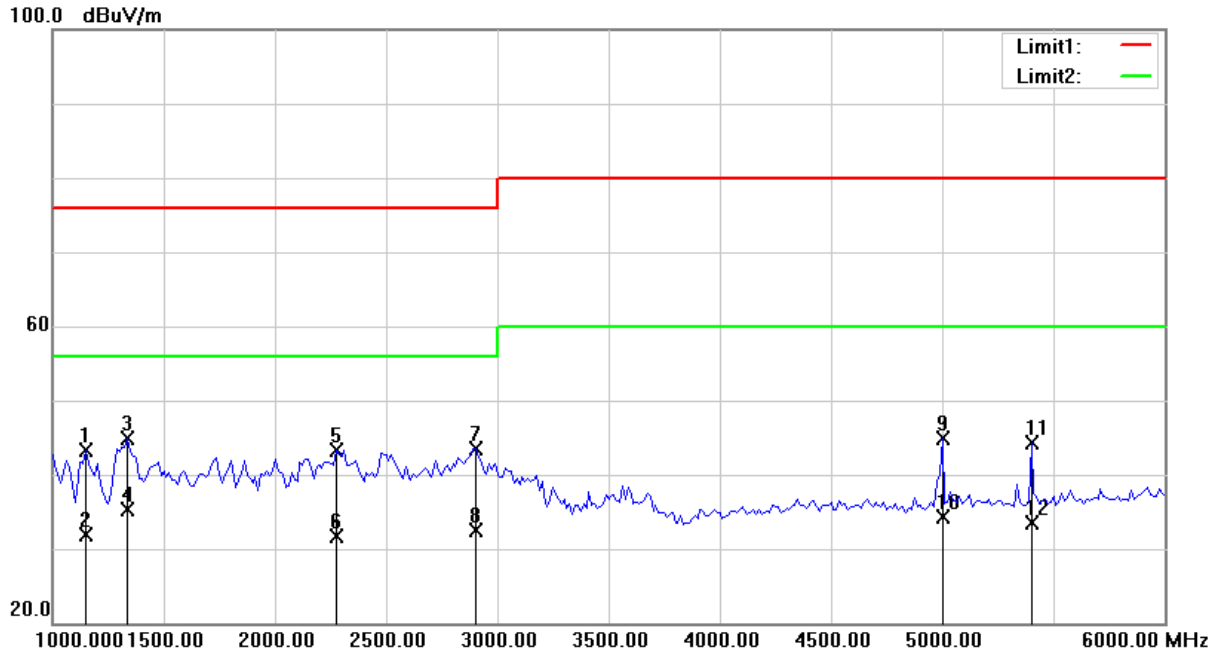

No.	Frequency (MHz)	Reading Level (dBμV)	Correct Factor (dB/m)	Measurement (dBμV/m)	Limit (dBμV/m)	Margin (dB)	Table Degree (degree)	Antenna Height (cm)	Detector
1	1150.000	62.53	-19.27	43.26	76.00	-32.74	149	100	peak
2	1150.000	51.27	-19.27	32.00	56.00	-24.00	149	100	AVG
3	1337.500	63.28	-18.29	44.99	76.00	-31.01	120	100	peak
4	1337.500	53.52	-18.29	35.23	56.00	-20.77	120	100	AVG
5	2275.000	57.92	-14.61	43.31	76.00	-32.69	180	100	peak
6	2275.000	46.35	-14.61	31.74	56.00	-24.26	180	100	AVG
7	2900.000	56.83	-13.31	43.52	76.00	-32.48	205	100	peak
8	2900.000	45.87	-13.31	32.56	56.00	-23.44	205	100	AVG
9	5000.000	53.13	-8.27	44.86	80.00	-35.14	202	100	peak
10	5000.000	42.57	-8.27	34.30	60.00	-25.70	202	100	AVG
11	5400.000	52.19	-7.85	44.34	80.00	-35.66	155	100	peak
12	5400.000	41.29	-7.85	33.44	60.00	-26.56	155	100	AVG

Remark: 1. peak = Peak, AVG = Average
 2. Correction Factor = Antenna factor + Cable loss (Antenna to preamplifier) - preamplifier Gain + Cable loss (preamplifier to receiver)
 3. Measurement Value = Reading Level + Correct Factor
 4. Margin Level = Measurement Value - Limit Value



Test Voltage	230Vac, 50Hz	Frequency Range	1 – 6GHz
Environmental Conditions	27°C, 55% RH	6dB Bandwidth	1MHz
Test Date	2024/07/08	Test Distance	3m
Tested by	Karwin Kao	Polarization	Horizontal
Test Site	W08-966-1		

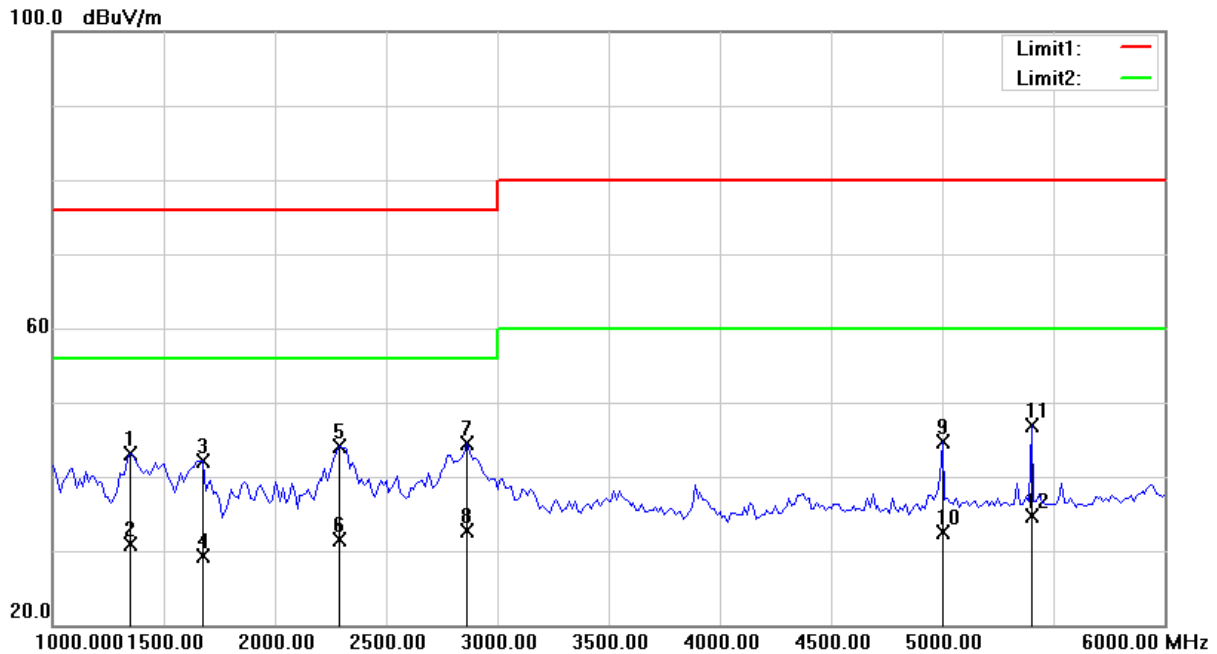

No.	Frequency (MHz)	Reading Level (dBμV)	Correct Factor (dB/m)	Measurement (dBμV/m)	Limit (dBμV/m)	Margin (dB)	Table Degree (degree)	Antenna Height (cm)	Detector
1	1350.000	61.43	-18.32	43.11	76.00	-32.89	216	100	peak
2	1350.000	49.28	-18.32	30.96	56.00	-25.04	216	100	AVG
3	1675.000	60.65	-18.53	42.12	76.00	-33.88	163	100	peak
4	1675.000	47.84	-18.53	29.31	56.00	-26.69	163	100	AVG
5	2287.500	58.80	-14.65	44.15	76.00	-31.85	150	100	peak
6	2287.500	46.11	-14.65	31.46	56.00	-24.54	150	100	AVG
7	2862.500	58.01	-13.44	44.57	76.00	-31.43	125	100	peak
8	2862.500	46.06	-13.44	32.62	56.00	-23.38	125	100	AVG
9	5000.000	52.93	-8.27	44.66	80.00	-35.34	213	100	peak
10	5000.000	40.71	-8.27	32.44	60.00	-27.56	213	100	AVG
11	5400.000	54.68	-7.85	46.83	80.00	-33.17	131	100	peak
12	5400.000	42.59	-7.85	34.74	60.00	-25.26	131	100	AVG

Remark: 1. peak = Peak, AVG = Average
 2. Correction Factor = Antenna factor + Cable loss (Antenna to preamplifier) - preamplifier Gain + Cable loss (preamplifier to receiver)
 3. Measurement Value = Reading Level + Correct Factor
 4. Margin Level = Measurement Value - Limit Value

4.3.7 Photographs of Test Configuration

Radiated Emission Test (30MHz~1GHz)

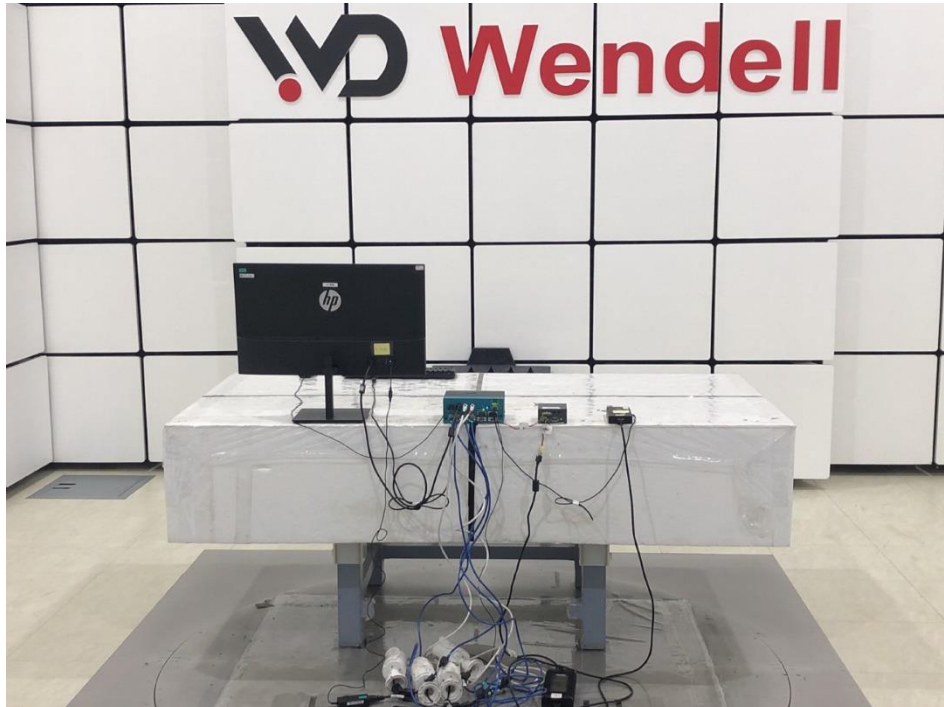

Radiated Emission Test (Above 1GHz)



4.4 Harmonics Current Measurement

4.4.1 Limits of Harmonics Current Measurement

The limits ensure that harmonic disturbance levels do not exceed the compatibility levels defined in IEC 61000-3-2.

Limits for Class A equipment	
Harmonics Order n	Max. permissible harmonics current A
Odd harmonics	
3	2.30
5	1.14
7	0.77
9	0.40
11	0.33
13	0.21
15<=n<=39	0.15x15/n
Even harmonics	
2	1.08
4	0.43
6	0.30
8<=n<=40	0.23x8/n

Limits for Class D equipment		
Harmonics Order n	Max. permissible harmonics current per watt mA/W	Max. permissible harmonics current A
Odd Harmonics only		
3	3.4	2.30
5	1.9	1.14
7	1.0	0.77
9	0.5	0.40
11	0.35	0.33
13	0.30	0.21
15<=n<=39	3.85/n	0.15x15/n

- Note:** 1. Class A and Class D are classified according to item section 5 of EN 61000-3-2.
 2. According to section 7 of EN 61000-3-2, the above limits for all equipment except for lighting equipment having an active input power > 75 W and no limits apply for equipment with an active input power up to and including 75 W.

4.4.2 Test Instrument

Item	Equipment	Manufacturer	Model	Meter No.	Calibration Date
1	Harmonics & Flicker Analyser	EMC PARTNER	HAR-1000-1P	CT-1-090(1)	Oct. 19, 2023
2	Power Source	EMC PARTNER	PS3-1	CT-1-090a1	Oct. 19, 2023

- Note:** 1. The calibration interval of the above test instruments is 12 months.

4.4.3 Test Procedure

The table-top EUT was placed on the top of a wooden table 0.8 meter above the ground and operated to produce the maximum harmonic under normal operating conditions for each successive harmonic component in turn. The floor-standing EUT was placed insulation support unit from the horizontal ground plane.

The classification of EUT is according to section 5 of EN 61000-3-2.

The EUT classified as follows:

Class A:

- Balanced three-phase equipment;
- Household appliances excluding equipment identified as Class D;
- Tools excluding portable tools;
- Dimmers for incandescent lamps;
- Audio equipment.

Equipment not specified in one of the three other classes should be considered as Class A equipment.

Note 1: Equipment that can be shown to have a significant effect on the supply system may be reclassified in a future edition of the standard. Factors to be taken into account include:

- Number in use;
- Duration of use;
- Simultaneity of use;
- Power consumption;
- Harmonic spectrum, including phase.

Class B:

- Portable tools;
- Arc welding equipment, which is not professional equipment.

Class C:

- Lighting equipment;

Class D:

Equipment having a specified power according to 6.2.2 less than or equal to 600W, of the following types:

- Personal computers and personal computer monitors;
- Television receivers.
- Refrigerators and freezers having one or more variable-speed drives to control compressor motor(s).

4.4.4 Deviation from Test Standard

No deviation

4.4.5 Test Setup

< Table-Top equipment >

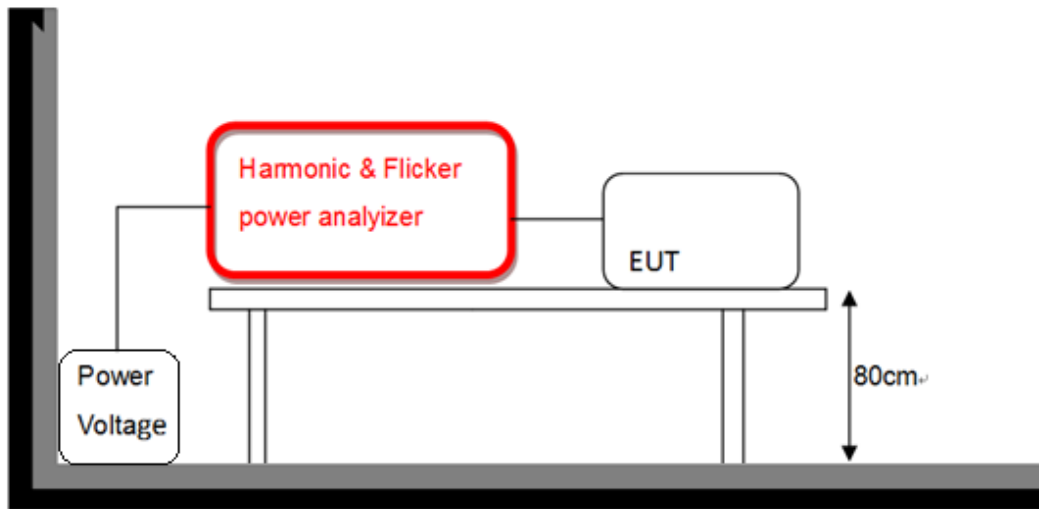

< Floor-Standing equipment >

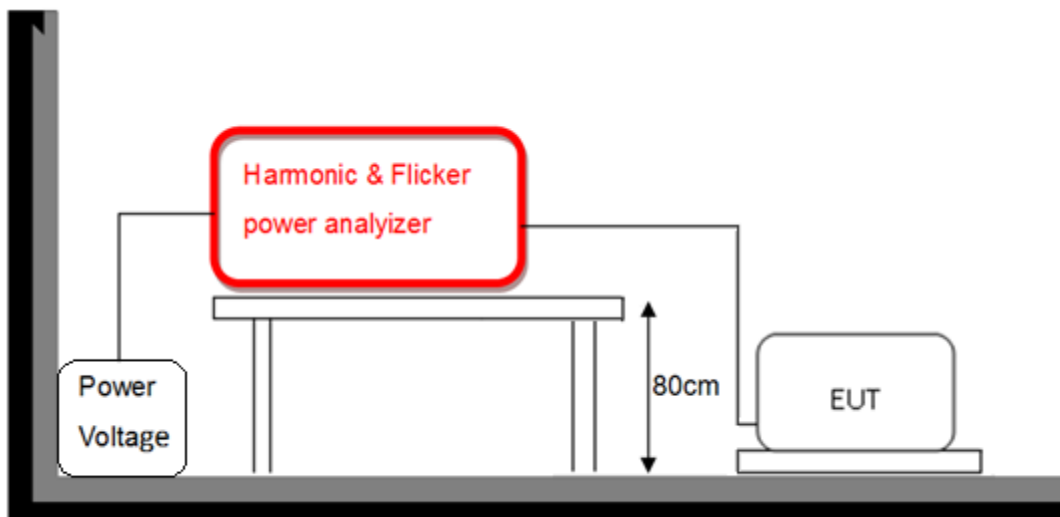

4.4.6 Test Result

Supply Voltage / Ampere	229.7 V _{rms} / 0.251 A _{rms}	Test Date	2024/07/03
Test Duration	5 min	Power Consumption	50.80W
Power Frequency	49.935Hz	Power Factor	0.881
Environmental Conditions	22°C, 50% RH	Tested by	Alan Chung

Note:

1. Limits are not specified for equipment with a rated power of 75W or less (other than lighting equipment).
2. According to EN 61000-3-2 the manufacturer shall specify the power of the apparatus. This value shall be used for establishing limits. The specified power shall be within +/-10% of the measured power.

4.4.7 Photographs of Test Configuration

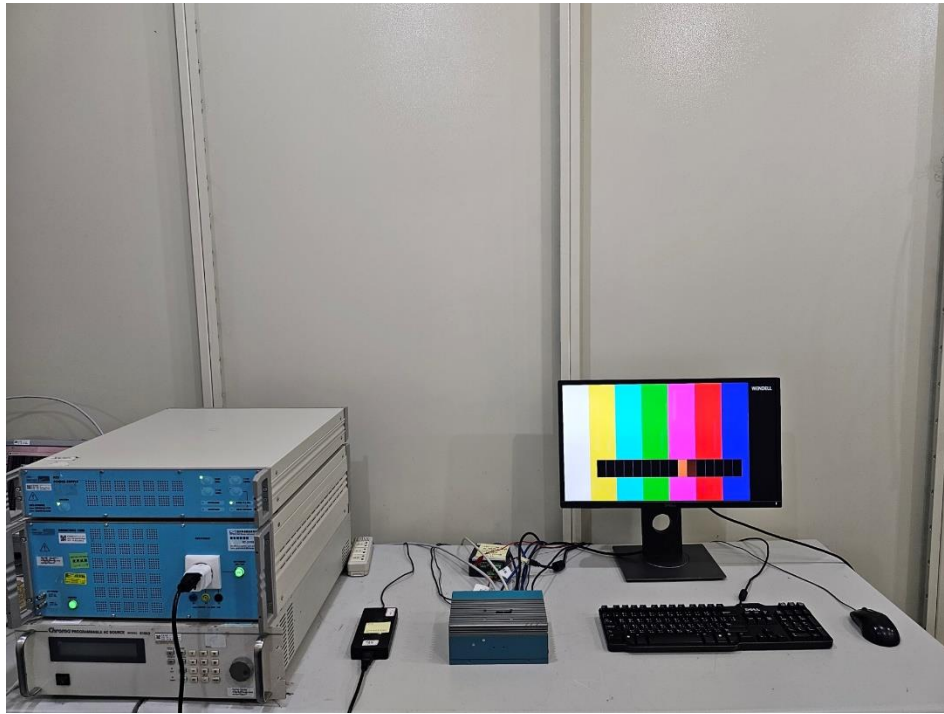

4.5 Voltage Fluctuation and Flicker Measurement

4.5.1 Limit for Voltage Function and Flicker Measurement

Tests Item	Limits	Remark
	IEC/EN 61000-3-3	
P _{st}	1.0, T _p = 10 min.	P _{st} means short-term flicker
P _{lt}	0.65, T _p =2 hr.	P _{lt} means long-term flicker
dc (%)	3.3%	dc means relative steady-state voltage change
d _{max} (%)	4%	d _{max} means maximum relative voltage change.
T _{dt}	3.3% / 500 ms	T _{dt} means maximum time that dt exceeds 3.3 %.

4.5.2 Test Instrument

Item	Equipment	Manufacturer	Model	Meter No.	Calibration Date
1	Harmonics & Flicker Analyser	EMC PARTNER	HAR-1000-1P	CT-1-090(1)	Oct. 19, 2023
2	Power Source	EMC PARTNER	PS3-1	CT-1-090a1	Oct. 19, 2023

Note: 1. The calibration interval of the above test instruments is 12 months.

4.5.3 Test Procedure

The table-top EUT was placed on the top of a wooden table 0.8 meter above the ground and operated to produce the most unfavorable sequence of voltage changes under normal operating condition. The floor-standing EUT was placed insulation support unit from the horizontal ground plane.

During the flick measurement, the measure time shall include that part of whole operation cycle in which the EUT produce the most unfavorable sequence of voltage changes. The observation period for short-term flicker indicator is 10 min and the observation period for long-term flicker indicator is 2 hours.

4.5.4 Deviation from Test Standard

No deviation

4.5.5 Test Setup

< Table-Top equipment >

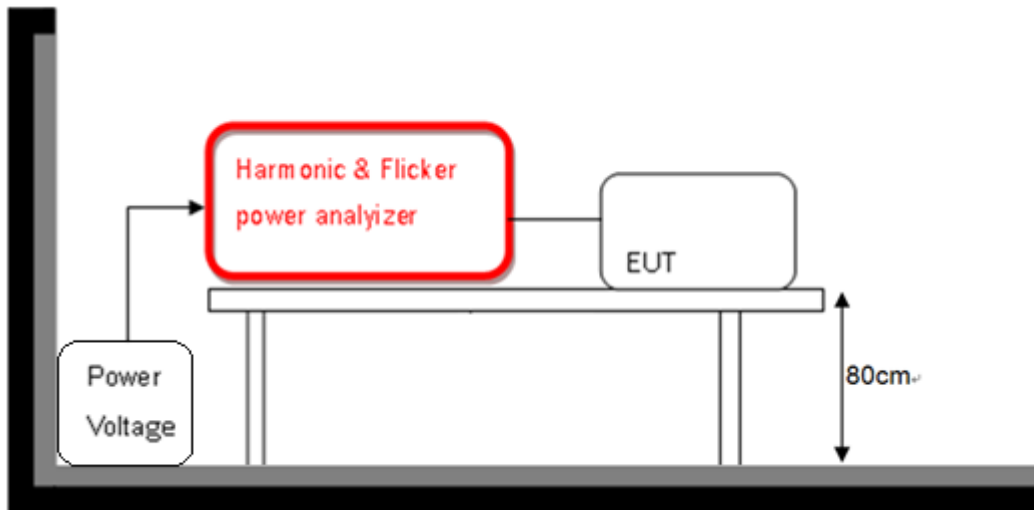

< Floor-Standing equipment >

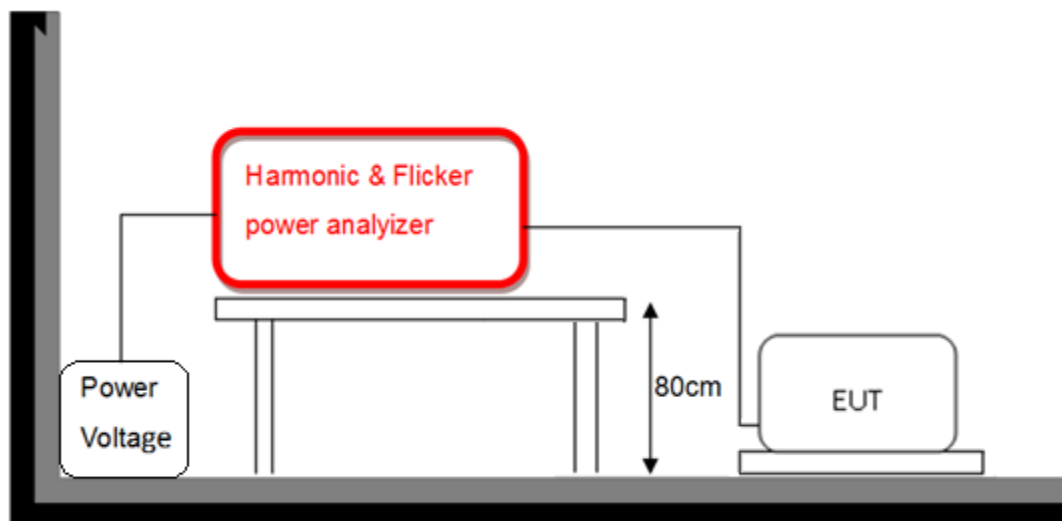



4.5.6 Test Result

Supply Voltage / Ampere	229.5 Vrms / 0.200 Arms	Test Date	2024/07/03
Observation (Tp)	30 min	Environmental Conditions	22°C, 50% RH
Power Frequency	49.922Hz	Tested by	Alan Chung

Test Parameter	Measurement Value	Test Limit	Remarks
P _{st}	0.07	1.00	Pass
P _{lt}	0.07	0.65	Pass
T _{dt} (ms)	0.00	500	Pass
d _{max} (%)	0.00	4%	Pass
dc (%)	0.01	3.3%	Pass

- Note:**
1. P_{st} means short-term flicker indicator.
 2. P_{lt} means long-term flicker indicator.
 3. T_{dt} means maximum time that dt exceeds 3.3 %.
 4. d_{max} means maximum relative voltage change.
 5. dc means relative steady-state voltage change.

4.5.7 Photographs of Test Configuration

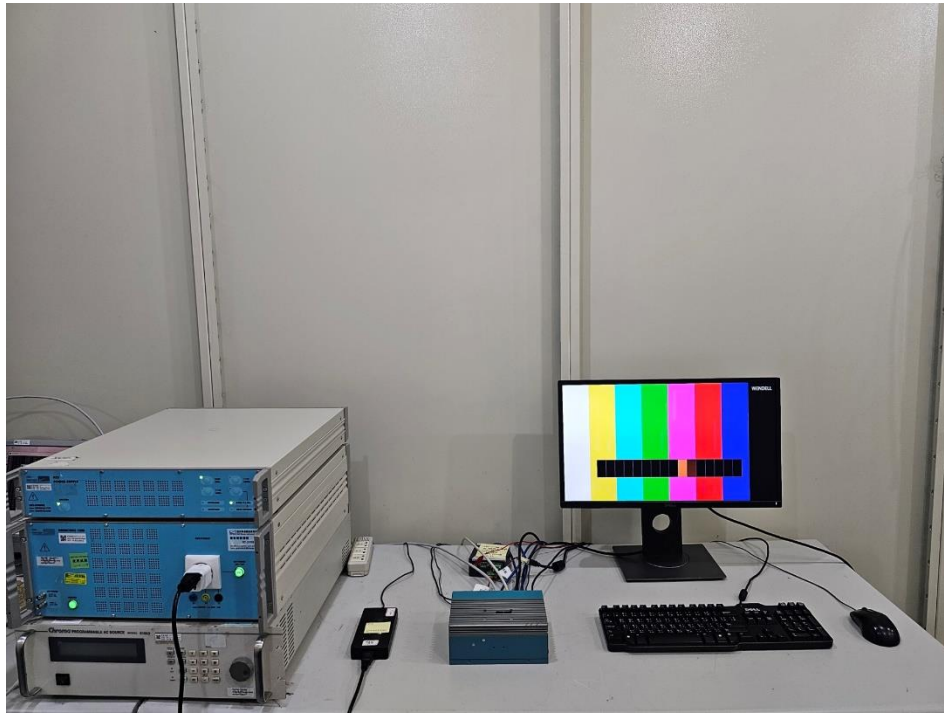

5 Immunity Test

5.1 Standard Description

Product standard	EN 55035	
Basic Standard and Performance Criterion required	IEC 61000-4-2 (ESD)	±4 kV Contact discharge, ±8 kV Air discharge, Performance Criterion B
	IEC 61000-4-3 (RS)	80 M ~ 1000 MHz, 3V/m(rms) , 80% AM (1kHz), 1800 MHz, 2600 MHz, 3500 MHz, 5000 MHz for spot test (Wireless communication device), 3V/m(rms), 80% AM (1kHz), Performance Criterion A
	IEC 61000-4-4 (EFT)	AC Main Power Port: ±1kV, DC Network Power Port (cable length > 3m): ±0.5 kV, Analogue/Digital Data Ports (cable length > 3m): ±0.5 kV, Performance Criterion B
	IEC 61000-4-5 (Surge)	AC Main Power Port: line to line ±1 kV, line to ground ±2 kV, DC Network Power Port (cable length > 3m): line to ground ±0.5 kV, Performance Criteria B Analogue/Digital Data Ports (unshielded symmetrical):line to ground Primary Protection: Intended, ±1 kV and ±4 kV, Primary Protection: Not Intended, ±1 kV, Performance Criteria C Analogue/Digital Data Ports (coaxial or shielded): shielded to ground, ±0.5 kV, Performance Criteria B
	IEC 61000-4-6 (CS)	AC Main Power Port, DC Network Power Port (cable length > 3m), Analogue/Digital Data Ports (cable length > 3m), 0.15 M ~ 10 MHz, 3Vrms, 80% AM, 1kHz, 10 M ~ 30 MHz, 3 - 1Vrms, 80% AM, 1kHz, 30 M ~ 80 MHz, 1Vrms, 80% AM, 1kHz, Performance Criterion A
	IEC 61000-4-8 (PFMF)	50Hz and 60Hz, 1 A/m, Performance Criterion A
	IEC 61000-4-11 (Dips)	Voltage Dips: >95% reduction, 0.5 period, Performance Criterion B 30% reduction, 25 period, Performance Criterion C Voltage Interruptions: >95% reduction, 250 period, Performance Criterion C

5.2 Performance Criteria

According to Clause 8 of EN 55035 standard, the general performance criteria as following:

Criteria A	The equipment shall continue to operate as intended without operator intervention. No degradation of performance, loss of function or change of operating state is allowed below a performance level specified by the manufacturer when the equipment is used as intended. The performance level may be replaced by a permissible loss of performance. If the minimum performance level or the permissible performance loss is not specified by the manufacturer, then either of these may be derived from the product description and documentation, and by what the user may reasonably expect from the equipment if used as intended.
Criteria B	During the application of the disturbance, degradation of performance is allowed. However, no unintended change of actual operating state or stored data is allowed to persist after the test. After the test, the equipment shall continue to operate as intended without operator intervention. No degradation of performance or loss of function is allowed, below a performance level specified by the manufacturer, when the equipment is used as intended. The performance level may be replaced by a permissible loss of performance. If the minimum performance level (or the permissible performance loss), or recovery time is not specified by the manufacturer, then either of these may be derived from the product description and documentation, and by what the user may reasonably expect from the equipment if used as intended.
Criteria C	Loss of function is allowed, provided the function is self-recoverable, or can be restored by the operation of the controls by the user in accordance with the manufacturer's instructions. A reboot or re-start operation is allowed. Information stored in non-volatile memory, or protected by a battery backup, shall not be lost.

5.3 Electrostatic Discharge (ESD)

5.3.1 Test Specification

Standard	IEC/EN 61000-4-2
Discharge Impedance	330 ohm / 150 pF
Discharge Voltage	Air Discharge: $\pm 2, \pm 4, \pm 8$ kV (Direct) Contact Discharge: ± 4 kV (Direct/Indirect)
Number of Discharge	Air: Minimum 10 times at each polarity Contact: Minimum 10 times at each polarity
Discharge Mode	Single Discharge
Discharge Period	1 second minimum

5.3.2 Test Instrument

Item	Equipment	Manufacturer	Model	Meter No.	Calibration Date
1	ESD Generator	TESEQ	NSG 437	CT-1-140	Jun. 15, 2024
2	ESD Generator	NoiseKen	ESS-B3011	CT-1-089	Aug. 04, 2023
3	Digital Thermo-Hygro Meter	N/A	HTC-8	CT-2-047	Jun. 06, 2023
4	Atmosphere pressure meter	TES	TES-1161	CT-5-094	Aug. 10, 2023

- Note:**
1. The calibration interval of the test instruments is 12 months.
 2. The calibration interval of thermo hygrometer/ Atmosphere pressure meter is 24 months.

5.3.3 Test Procedure

The test generator necessary to perform direct and indirect application of discharge to the EUT in following methods:

a. Contact discharges to the conductive surface and coupling planes:

For table-top equipment one of the test points shall be the centre front edge of the horizontal coupling plane, which shall be subjected to at least 20 indirect discharges (10 of each polarity). All other test points shall each receive at least 20 direct contact discharges (10 of each polarity). All areas normally touched by the user should be tested. Test shall be performed at a maximum repetition rate of one discharge per second.

Vertical Coupling Plane (VCP):

The coupling plane, of dimensions 0.5 m × 0.5 m, is placed parallel to, and positioned at a distance 0.1 m from, the EUT, with the discharge electrode touching the coupling plane. The four faces of the EUT will be performed with electrostatic discharge.

Horizontal Coupling Plane (HCP):

The coupling plane, of dimensions 1.6 m × 0.8 m, is placed under the EUT. The generator shall be positioned vertically a distance of 0.1 m from the EUT, with the discharge electrode touching the coupling plane. The four faces of the EUT will be performed with electrostatic discharge.

b. Air discharge at apertures and slots and insulating surface:

On those parts of the EUT where it is not possible to perform contact discharge testing, the equipment should be investigated to identify user accessible points where breakdown may occur. Such points are tested using the air discharge method. This investigation should be restricted to those area normally handled by the user. A minimum 10 single air discharges shall be applied to the selected test point for each such area.

5.3.4 Deviation from Test Standard

No deviation

5.3.5 Test Setup

< Table-Top equipment >

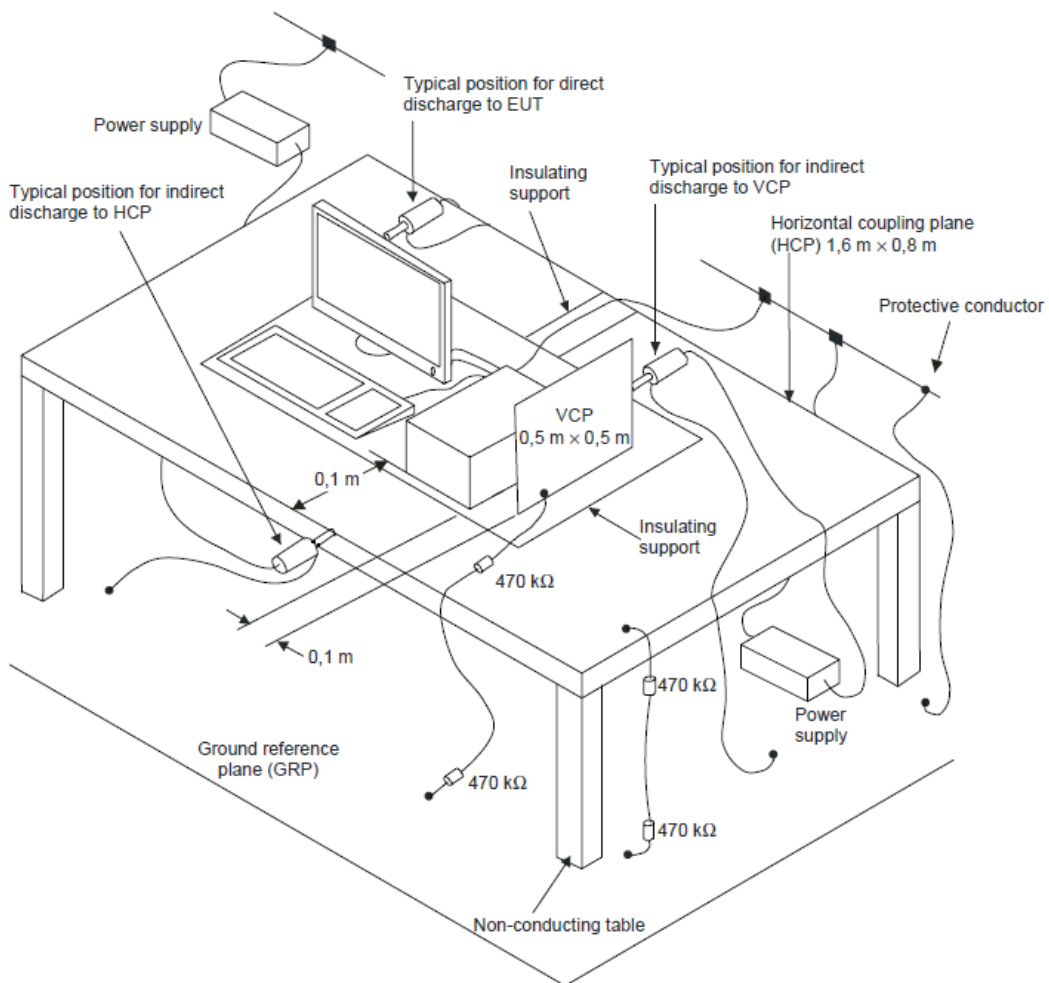

< Floor-Standing equipment >

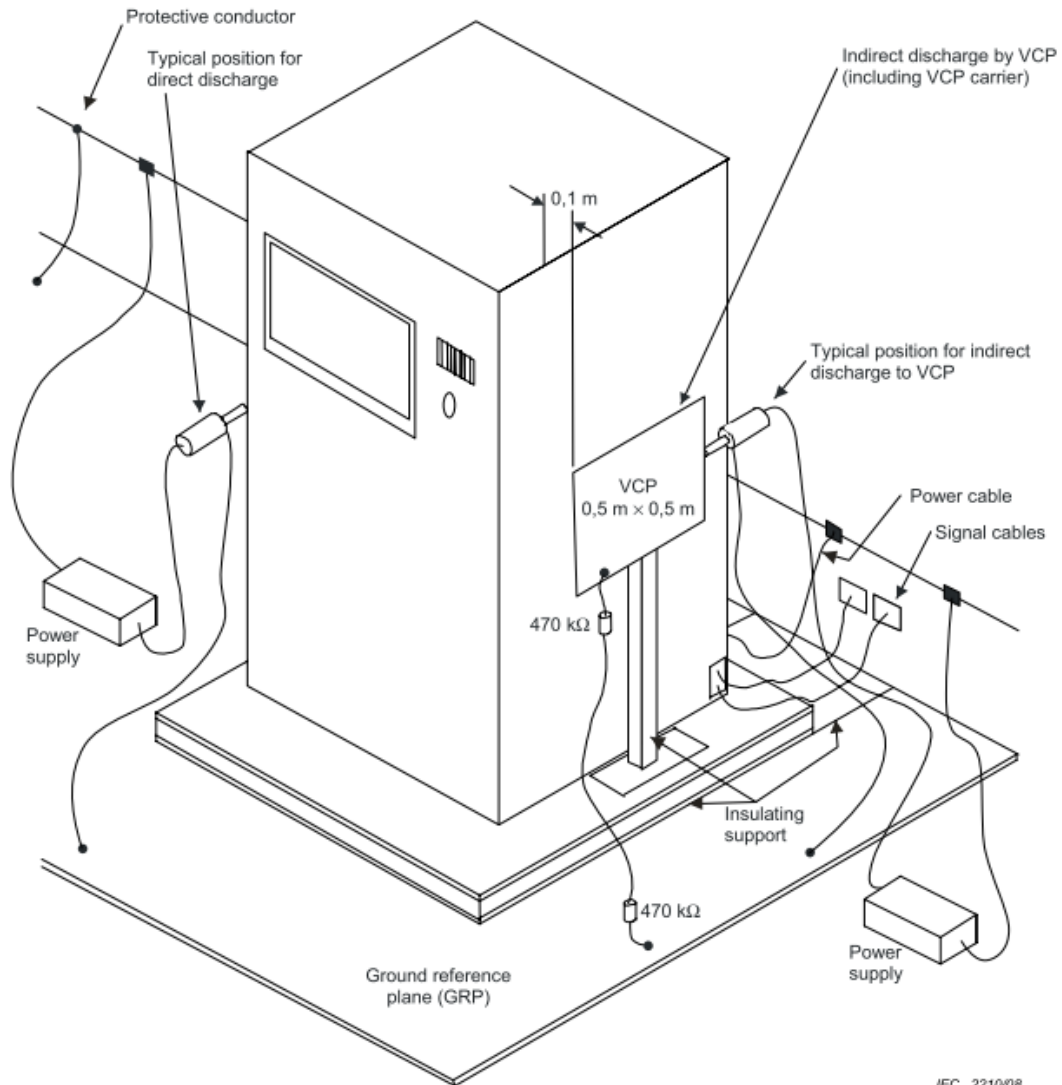

IEC 2210/08



5.3.6 Test Result

Test Voltage	230Vac, 50Hz	Test Date	2024/07/11
Environmental Conditions	24°C, 53% RH	Pressure	1001 mbar
Tested by	Guanwei Liao		

Test Results of Direct Application

Air Discharge				
Test Point	Discharge Level (kV)			Result
	±2	±4	±8	
Front	A (#1)	A (#1)	A (#1)	A
Back	N/A	N/A	N/A	N/A
Left	N/A	N/A	N/A	N/A
Right	N/A	N/A	N/A	N/A
Top	N/A	N/A	N/A	N/A
Bottom	N/A	N/A	N/A	N/A
Other	N/A	N/A	N/A	N/A

* Test location(s) in which discharge to be applied illustrated by photos shown in next page(s).

Contact Discharge			
Test Point	Discharge Level (kV)		Result
	±4		
Front	B (#1)		B
Back	A		A
Left	A		A
Right	A		A
Top	A		A
Bottom	A		A
Other	N/A		N/A

* Test location(s) in which discharge to be applied illustrated by photos shown in next page(s).

**Test Results of Indirect Application**

HCP Discharge		
Test Point	Discharge Level (kV)	Result
	±4	
Front	A	A
Back	A	A
Left	A	A
Right	A	A

VCP Discharge		
Test Point	Discharge Level (kV)	Result
	±4	
Front	A	A
Back	A	A
Left	A	A
Right	A	A

Note:

N/A: Not applicable

Criteria A: The EUT function was correct during the test.

Criteria A: (#1) No occur arcing.

Criteria B: (#1) The EUT was interrupted during the test, but could self-recover to the normal mode after the test.

Description of Test Points

Front



Back

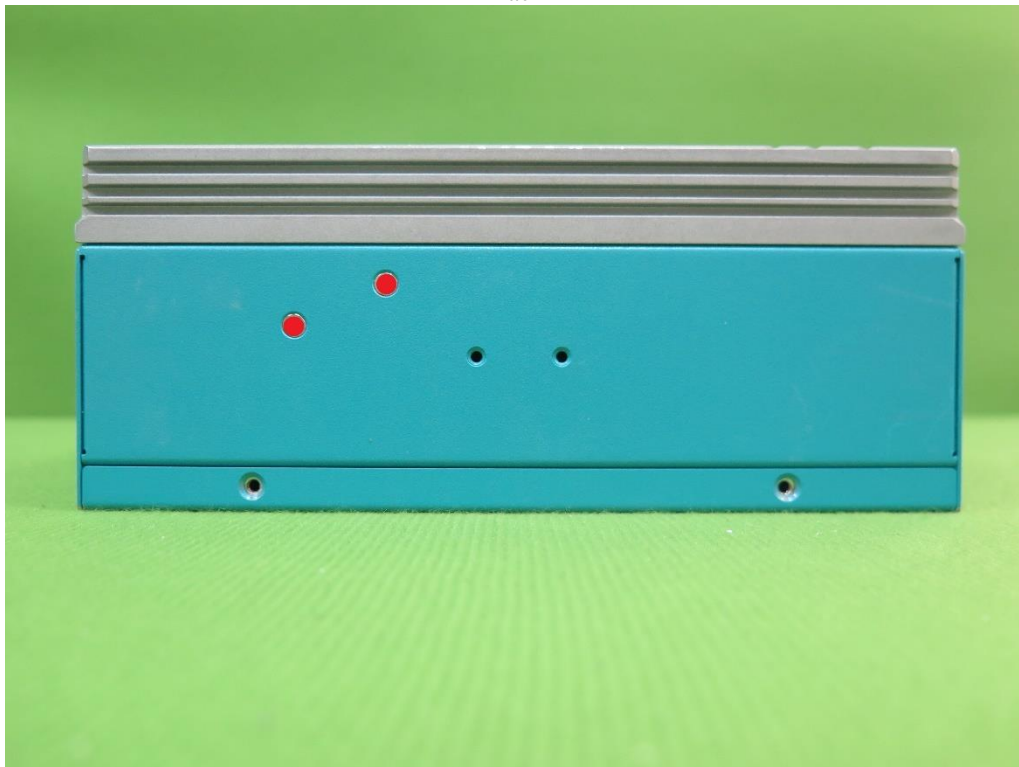

*Red Dot - Contact Discharged
Blue Dot - Air Discharged

Left

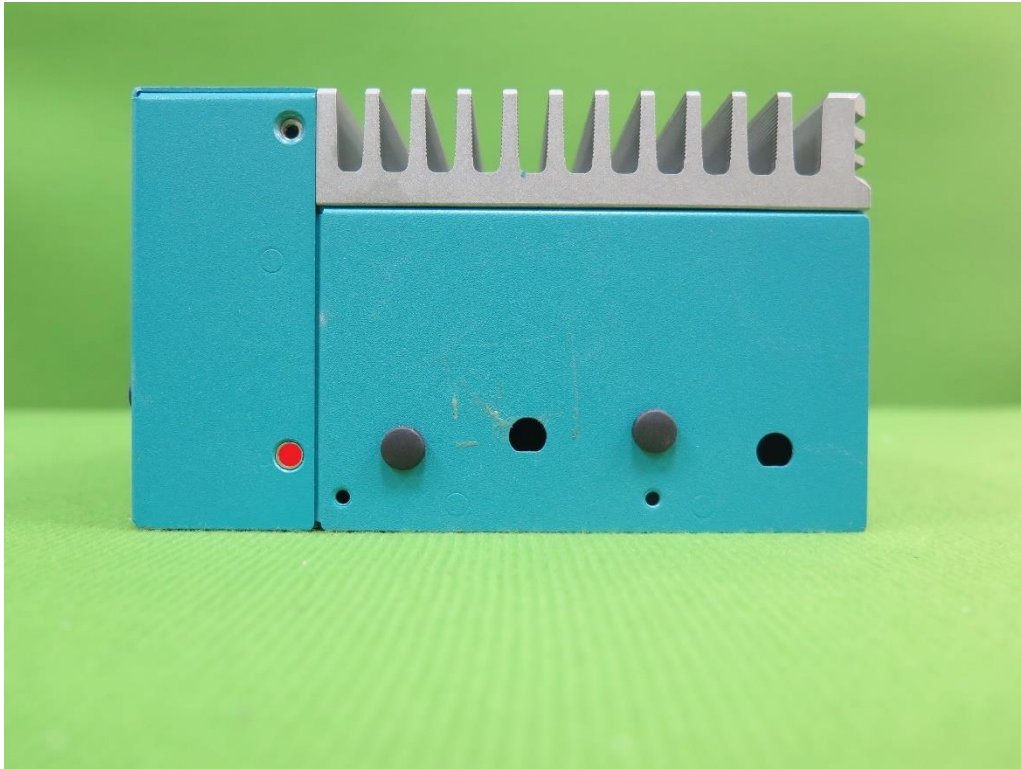

Right



*Red Dot - Contact Discharged
Blue Dot - Air Discharged

Top

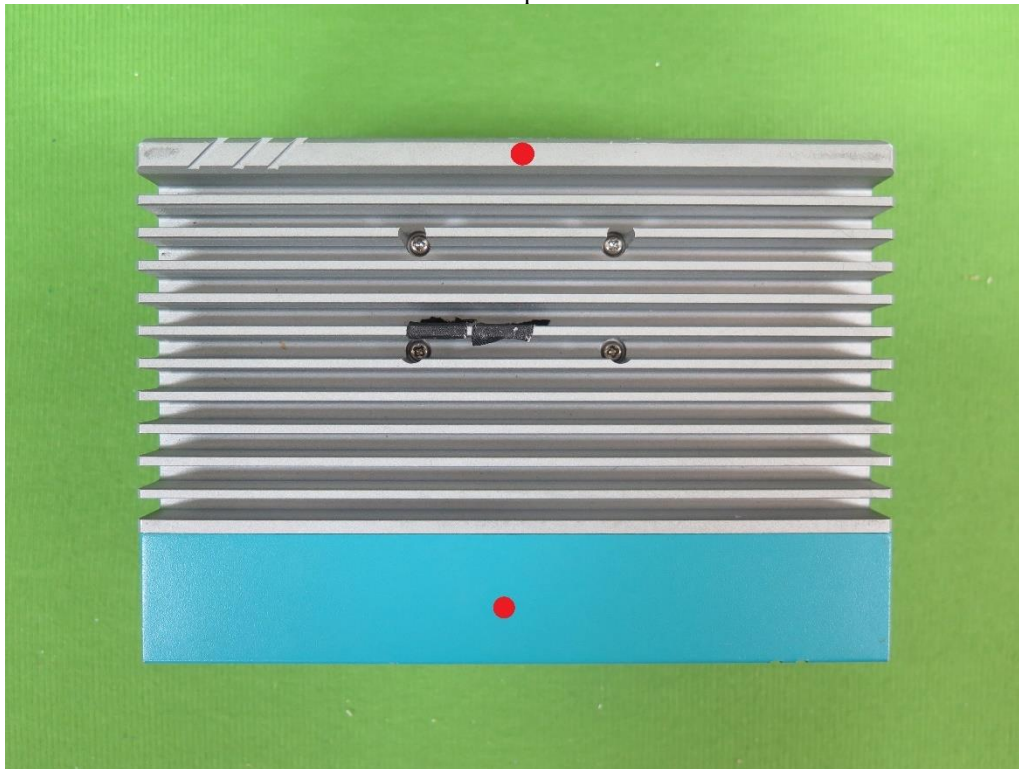

Bottom

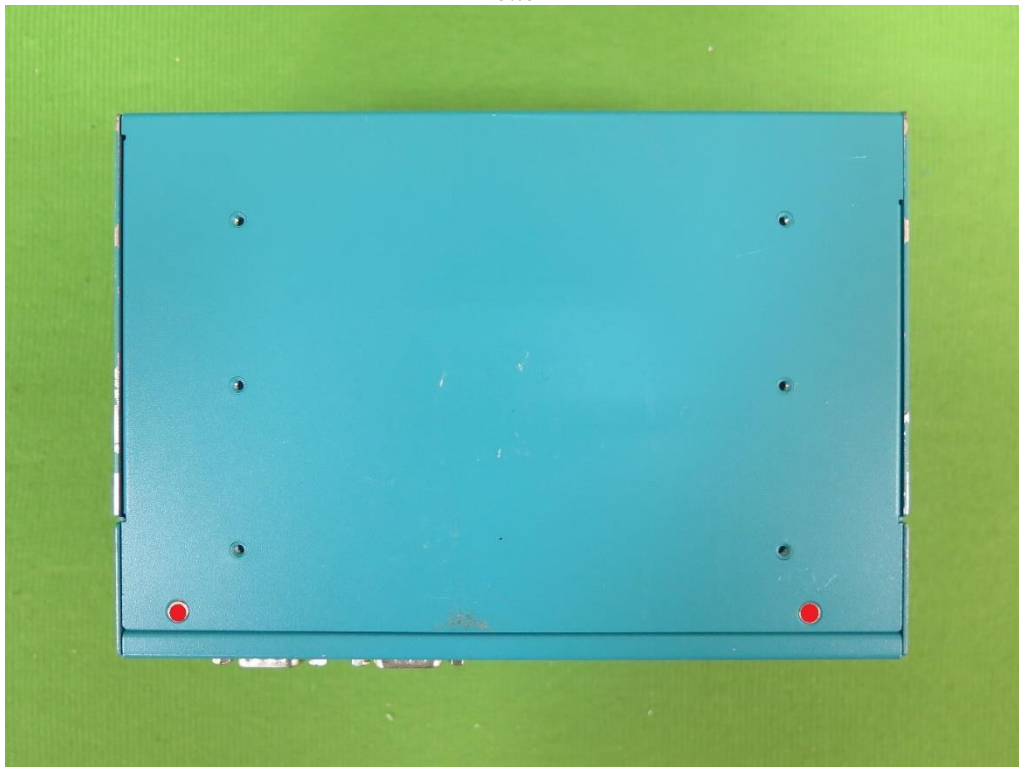

*Red Dot - Contact Discharged
Blue Dot - Air Discharged

5.3.7 Photographs of Test Configuration



5.4 Radiated, Radio-frequency, Electromagnetic Field Immunity Test (RS)

5.4.1 Test Specification

Standard	IEC/EN 61000-4-3
Frequency Range	80MHz - 1000MHz 1800MHz, 2600MHz, 3500MHz, 5000MHz for spot test
Field Strength	3 V/m
Modulation	80%, AM Modulation 1 kHz Sine Wave
Frequency Step	1%
Polarity of Antenna	Horizontal and Vertical
Test Distance	2.15 m (80MHz - 1000MHz) 1 m (1GHz - 6GHz)
Antenna Height	1.5 m (80MHz - 1000MHz) 1 m (1GHz - 6GHz)
Dwell Time	3 seconds or not exceed 5 seconds

5.4.2 Test Instrument

Item	Equipment	Manufacturer	Model	Meter No.	Calibration Date
1	RadiCentre ® Modular EMC Test Systems	DARE	CTR1004B	CT-1-080	No calibration request
2	RF Signal Generator	DARE	RGN6000B	CT-1-080	Aug. 06, 2023
3	LINEAR POWER RF AMPLIFIER	TESEQ	CBA1G-300 D	CT-1-163	Aug. 06, 2023
4	LINEAR POWER RF AMPLIFIER	OPHIR	5193	CT-1-083	Aug. 06, 2023
5	LINEAR POWER RF AMPLIFIER	FRANKONIA	FLG-30C	CT-1-061	Aug. 06, 2023
6	Periodic Test-Antenna	Schwarzbeck Mess - Elektronik	STLP 9128 E	CT-1-085	No calibration request
7	Stacked Microwave Log.-Per. Antenna	Schwarzbeck Mess - Elektronik	STLP 9149	CT-1-086	No calibration request
8	Electric Field Probe	FRANKONIA	EFS-10	CT-1-060a1	Sep. 29, 2023
9	Measurement Software	EMC-RS	Ver: 2.0.1.3	N/A	No calibration request

Note: 1. The calibration interval of the above test instruments is 12 months.

5.4.3 Test Procedure

The test procedure was in accordance with IEC 61000-4-3.

The table-top EUT and load, which are placed on a table that is 0.8 meter above ground, are placed with one coincident with the calibration plane such that the distance from antenna to the EUT was 2.15 meter at test frequency 80M - 1GHz. (The distance was 1 meter at test frequency 1G - 6GHz)

Both horizontal and vertical polarization of the antenna and four sides of the EUT are set on measurement.

The EUT shall be positioned so that the four sides of the EUT shall be exposed to the electromagnetic field in sequence. In each position the performance of the EUT will be investigated.

In the case where the most sensitive surface side of the EUT is known throughout the frequency range (for example, via preliminary tests), testing may be restricted to that surface side only. Where it is not possible to determine the most sensitive face with any certainty (for example where different faces are sensitive at different frequencies) all four faces shall be tested.

If the EUT is too large such that it cannot be fully illuminated by the radiating antenna, or exceeds the size of the Uniform Field Area (UFA) then partial illumination shall be used. The EUT can be repositioned so that the front surface remains within the UFA in order to illuminate those sections of the EUT that were previously outside the UFA.

In order to judge the EUT performance, a CCD camera is used to monitor EUT screen.

All the scanning conditions are as follows:

	Condition of Test	Remarks
1	Field Strength	3V/m
2	Radiated Signal	AM 80% Modulated with 1kHz
3	Scanning Frequency	80M - 1000MHz
4	Spot Frequency for Wireless communication device	1800MHz, 2600MHz, 3500MHz, 5000MHz
5	Dwell Time	3.0 seconds or not exceed 5 seconds
6	Frequency Step Size Δf	1%

5.4.4 Deviation from Test Standard

No deviation

5.4.5 Test Setup

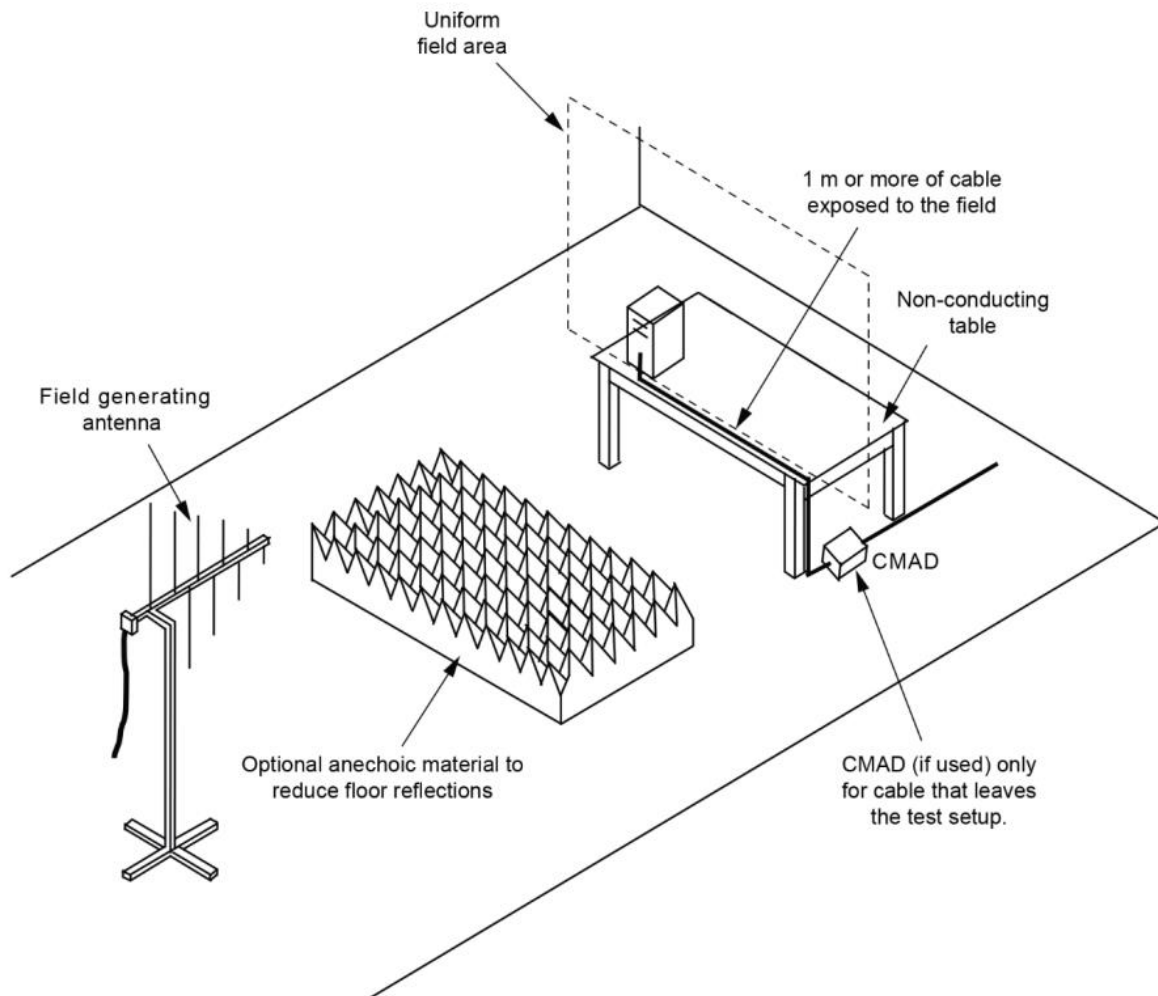



5.4.6 Test Result

Test Voltage	230Vac, 50Hz	Environmental Conditions	24°C, 50% RH
Tested by	Dennis Chen	Test Date	2024/07/02

Frequency Range (MHz)	Azimuth	Polarity	Field Strength (V/m)	Modulation	Result
80-1000	0, 90, 180, 270	H/V	3	80% AM (1kHz)	A
1800	0, 90, 180, 270	H/V	3	80% AM (1kHz)	A
2600	0, 90, 180, 270	H/V	3	80% AM (1kHz)	A
3500	0, 90, 180, 270	H/V	3	80% AM (1kHz)	A
5000	0, 90, 180, 270	H/V	3	80% AM (1kHz)	A

Note:

Criteria A: The EUT function was correct during the test.

5.4.7 Photographs of Test Configuration



5.5 Electrical Fast Transient /Burst Immunity Test (EFT)

5.5.1 Test Specification

Standard	IEC/EN 61000-4-4
Test Voltage	AC Main Power Port: ± 1 kV, DC Network Power Port ^(Note 1) (cable length > 3m): ± 0.5 kV, Analogue/Digital Data Ports (cable length > 3m): ± 0.5 kV,
Polarity	Positive & Negative
Impulse Frequency	CPE xDSL Ports: 100kHz Other: 5kHz
Impulse Wave	5/50 ns
Burst Duration	15 ms
Burst Period	300 ms
Test Duration	Not less than 1 min.

Note: 1. Applicable only to port which, according to the manufacturer's specification, support cabled lengths greater than 3m.

5.5.2 Test Instrument

Item	Equipment	Manufacturer	Model	Meter No.	Calibration Date
1	EFT Generator	3ctest	EFT500S	CT-1-165	Sep. 20, 2023
2	Clamp	3ctest	CCC100	CT-1-166	Sep. 20, 2023

Note: 1. The calibration interval of the above test instruments is 12 months.

5.5.3 Test Procedure

The table-top EUT was placed on a table that is 0.8 meter height. A ground reference plane is placed on the table, and uses 0.1m insulation between the EUT and ground reference plane. The floor-standing EUT was placed on 0.1m insulation support unit between the EUT and ground reference plane.

The minimum area of the ground reference plane is $1\text{m} \times 1\text{m}$, and 0.65mm thick min, and projected beyond the EUT by at least 0.1m on all sides.

For input power ports:

The EUT is connected to the power ports through a coupling device that directly couples the EFT/B interference signal. Each of the line conductors is impressed with burst noise for 1 minute. The length of the power lines between the coupling device and the EUT is 0.5m.

5.5.4 Deviation from Test Standard

No deviation

5.5.5 Test Setup

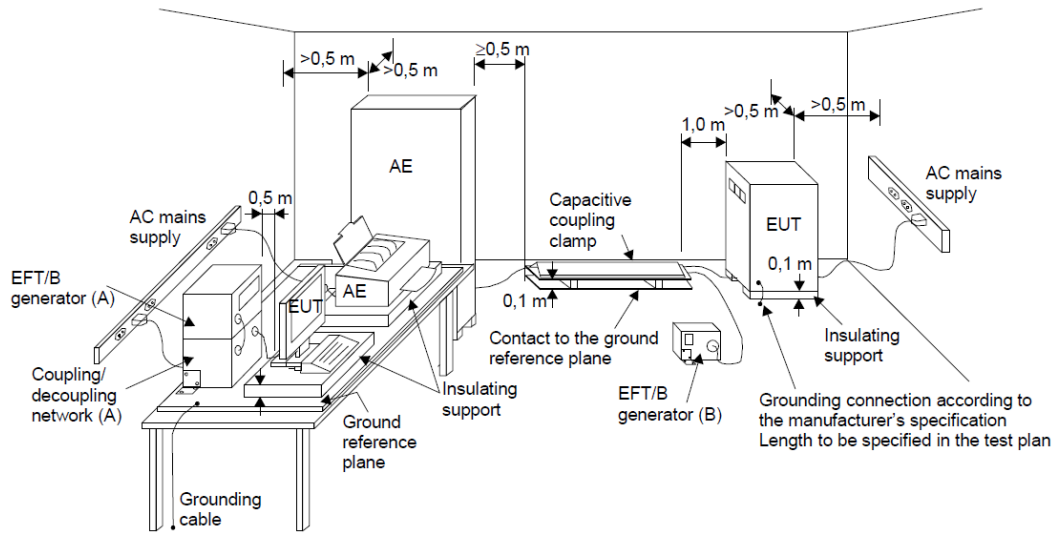

- (A) location for supply line coupling
- (B) location for signal lines coupling

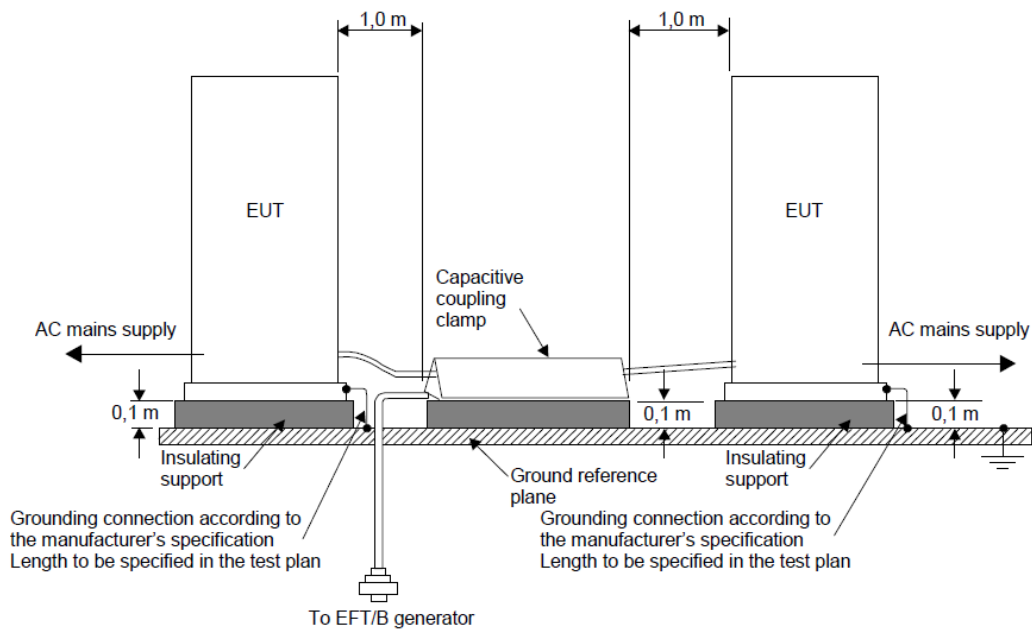



5.5.6 Test Result

Test Voltage	230Vac, 50Hz	Environmental Conditions	22°C, 50% RH
Tested by	Alan Chung	Test Date	2024/05/31

Test Point		Test Level (kV)	Polarity (+/-)	Result
AC Power Port	L	1	+/-	A
	N	1	+/-	A
	PE	1	+/-	A
	L + N	1	+/-	A
	L + PE	1	+/-	A
	N + PE	1	+/-	A
	L + N + PE	1	+/-	A
Signal Ports Telecommunication Ports	RJ45	0.5	+/-	A
	PoE	0.5	+/-	A

Note:

Criteria A: The EUT function was correct during the test.

5.5.7 Photographs of Test Configuration

Power



Signal



PoE



5.6 Surge Immunity Test

5.6.1 Test Specification

Standard	IEC/EN 61000-4-5
Wave- Shape	<p>AC Main Power Port: 1.2/50 μs Open Circuit Voltage, 8/20 μs Short Circuit Current</p> <p>DC Network Power Port ^(Note 1): 1.2/50 μs Open Circuit Voltage, 8/20 μs Short Circuit Current</p> <p>Analogue/Digital Data Ports (unshielded symmetrical) (Direct to outdoor cables^(Note 2, 3)): 10/700 μs Open Circuit Voltage, 5/320 μs Short Circuit Current</p> <p>Analogue/Digital Data Ports (coaxial or shielded) (Direct to outdoor cables^(Note 2, 3)): 1.2/50 μs Open Circuit Voltage, 8/20 μs Short Circuit Current</p>
Test Voltage	<p>AC Main Power Port: line to line ± 1 kV, line to ground ± 2 kV,</p> <p>DC Network Power Port (cable length > 3m): line to ground ± 0.5 kV,</p> <p>Analogue/Digital Data Ports (unshielded symmetrical): line to ground</p> <p>Primary Protection: Intended ± 1 kV and ± 4 kV, Primary Protection: Not Intended ± 1 kV,</p> <p>Analogue/Digital Data Ports (coaxial or shielded): shielded to ground ± 0.5 kV</p>
Surge Input / Output	L1-L2, L1-PE, L2-PE
Polarity	Positive/Negative
Phase Angle	0°/90°/180°/270° (For AC Power Port)
Pulse Repetition Rate	1 time / min. (maximum)
Times	5 Positive and 5 Negative at selected points

- Note:**
1. Applicable only to port which, according to the manufacturer's specification, support cabled lengths greater than 3 m.
 2. Surges are applied with primary protection fitted. Where possible, use the actual primary protector intended to be used in the installation. Where the surge coupling network for the 10/700 (5/320) μ s wave affects the functioning of high speed data ports, the test shall be carried out using 1.2/50 (8/20) μ s wave and appropriate coupling network.
 3. Surges are applicable to ports which satisfy all the following conditions:
May connect directly to cables that leave the building structure.
Defined as an antenna port, a wired network, or a broadcast receiver tuner port.
Typical port covered include xDSL, PSTN, CATV, antenna and similar. Exclude ports are LAN and similar.

5.6.2 Test Instrument

Item	Equipment	Manufacturer	Model	Meter No.	Calibration Date
1	Surge Generator	HAEFELY	AXOS8	CT-1-059(1)	Aug. 07, 2023
2	Surge CDN	3cTest	CDN-405T8A1	CT-1-074(5)	May 27, 2024

Note: 1. The calibration interval of the above test instruments is 12 months.

5.6.3 Test Procedure

The EUT is placed on a table that is 0.8 meter above a metal ground plane measured 1m × 1m minimum and 0.65mm thick minimum and projected beyond the EUT by at least 0.1m on all sides. The length of power cord between the coupling device and the EUT shall be 2m or less.

For input power ports:

The EUT is connected to the power ports through a coupling device that directly couples the surge interference signal.

The surge noise shall be applied synchronized to the peak value of the voltage wave. (Positive and negative)

Each of Line to Earth and Line to Line is impressed with a sequence of five surge voltages with interval of 1 minute.

5.6.4 Deviation from Test Standard

No deviation

5.6.5 Test Setup

< Table-Top equipment >

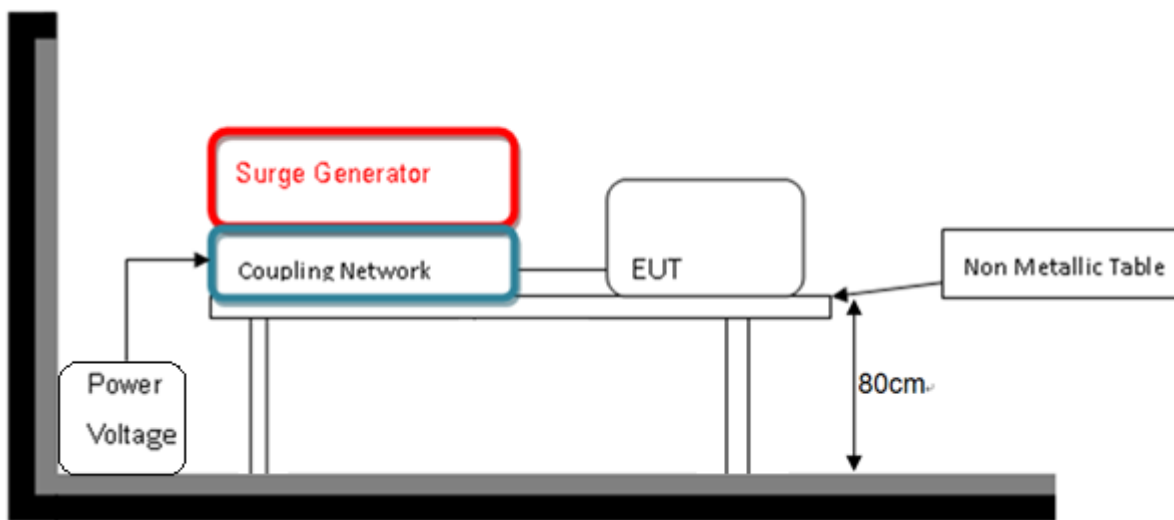

< Floor-Standing equipment >

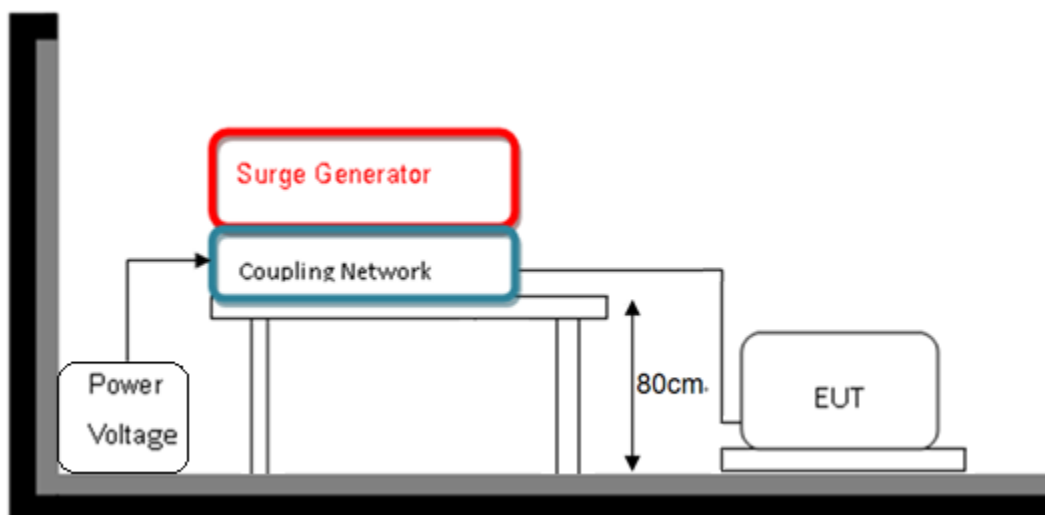



5.6.6 Test Result

Test Voltage	230Vac, 50Hz	Environmental Conditions	22°C, 54% RH
Tested by	Guanwei Liao	Test Date	2024/07/10

AC Power Port						
Test Point	Phase	Polarity (+/-)	Test Voltage (kV)			Result
			0.5	1	2	
L to N	0°	+/-	A	A	-	A
	90°	+/-	A	A	-	
	180°	+/-	A	A	-	
	270°	+/-	A	A	-	
L to PE	0°	+/-	A	A	A	A
	90°	+/-	A	A	A	
	180°	+/-	A	A	A	
	270°	+/-	A	A	A	
N to PE	0°	+/-	A	A	A	A
	90°	+/-	A	A	A	
	180°	+/-	A	A	A	
	270°	+/-	A	A	A	

Note:

Criteria A: The EUT function was correct during the test.

5.6.7 Photographs of Test Configuration



5.7 Continuous Conducted Disturbances (CS)

5.7.1 Test Specification

Standard	IEC/EN 61000-4-6
Frequency Range	0.15 ~ 10 MHz, 10 ~ 30 MHz, 30 ~ 80 MHz,
Voltage Level	3 V(rms), 3 - 1 V(rms), 1 V(rms)
Modulation	AM Modulation, 80%, 1 kHz Sine Wave
Frequency Step	1% of fundamental
Dwell Time	3 seconds

5.7.2 Test Instrument

Item	Equipment	Manufacturer	Model	Meter No.	Calibration Date
1	Coupling clamp according to IEC 6100-4-6	FRANKONIA	EMCL-20	CT-1-049	May 30, 2024
2	CDN for power supply lines	FRANKONIA	CDN M2+M3	CT-1-054	May 30, 2024
3	6 dB Attenuator	BIRD	75-A-FFN-06	CT-1-056	May 30, 2024
4	Compact Immunity Test System acc	FRANKONIA	CIT-10/75	CT-1-057	May 30, 2024
5	CDN for screened lines	FRANKONIA	RJ45S	CT-1-052 (1)	May 30, 2024
6	50ohm Termination	N/A	N/A	CT-1-065-1	May 30, 2024
7	CDN Four Balanced Pairs-unscreened	Com-Power	CDN-T8E	CT-1-130	May 30, 2024
8	Measurement Software	HUBERT	Ver: 1.1.2	N/A	No calibration request

Note: 1. The calibration interval of the above test instruments is 12 months.

5.7.3 Test Procedure

The EUT is placed on 0.1m insulation support unit between the EUT and ground reference plane.

For input power ports:

The EUT is connected to the power ports through a coupling and decoupling networks for power supply lines. And directly couples the disturbances signal into EUT.

Auxiliary equipment (AE) required for the defined operation of the EUT according to the specifications of the product committee.

5.7.4 Deviation from Test Standard

No deviation

5.7.5 Test Setup

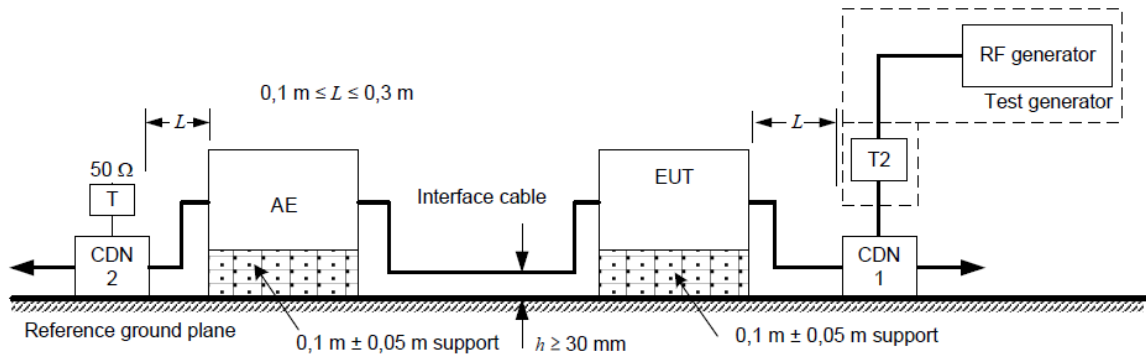

The interface cable is set at 1 m if possible.

a) Schematic setup for a 2-port EUT connected to only 1 CDN

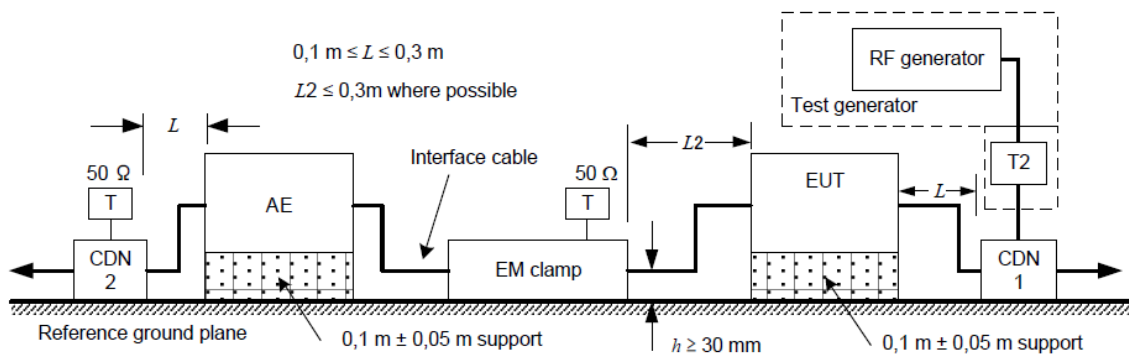

Note:

T: Termination 50 Ω

T2: Power attenuator (6 dB)

CDN: Coupling and decoupling network

Injection clamp: current clamp or EM clamp



5.7.6 Test Result

Test Voltage	230Vac, 50Hz	Environmental Conditions	24°C, 50% RH
Tested by	Dennis Chen	Test Date	2024/06/24

Frequency Range (MHz)	Tested Port	Injection Method	Test Level (V _{r.m.s.})	Modulation	Result
0.15 - 10	AC Power	CDN-M2 +M3(M3)	3	80% AM, 1kHz	A
10 - 30	AC Power	CDN-M2 +M3(M3)	3 - 1	80% AM, 1kHz	A
30 - 80	AC Power	CDN-M2 +M3(M3)	1	80% AM, 1kHz	A
0.15 - 10	RJ45	RJ45S	3	80% AM, 1kHz	A
10 - 30	RJ45	RJ45S	3 - 1	80% AM, 1kHz	A
30 - 80	RJ45	RJ45S	1	80% AM, 1kHz	A
0.15 - 10	PoE	RJ45S	3	80% AM, 1kHz	A
10 - 30	PoE	RJ45S	3 - 1	80% AM, 1kHz	A
30 - 80	PoE	RJ45S	1	80% AM, 1kHz	A

Note:

Criteria A: The EUT function was correct during the test.

5.7.7 Photographs of Test Configuration

Power

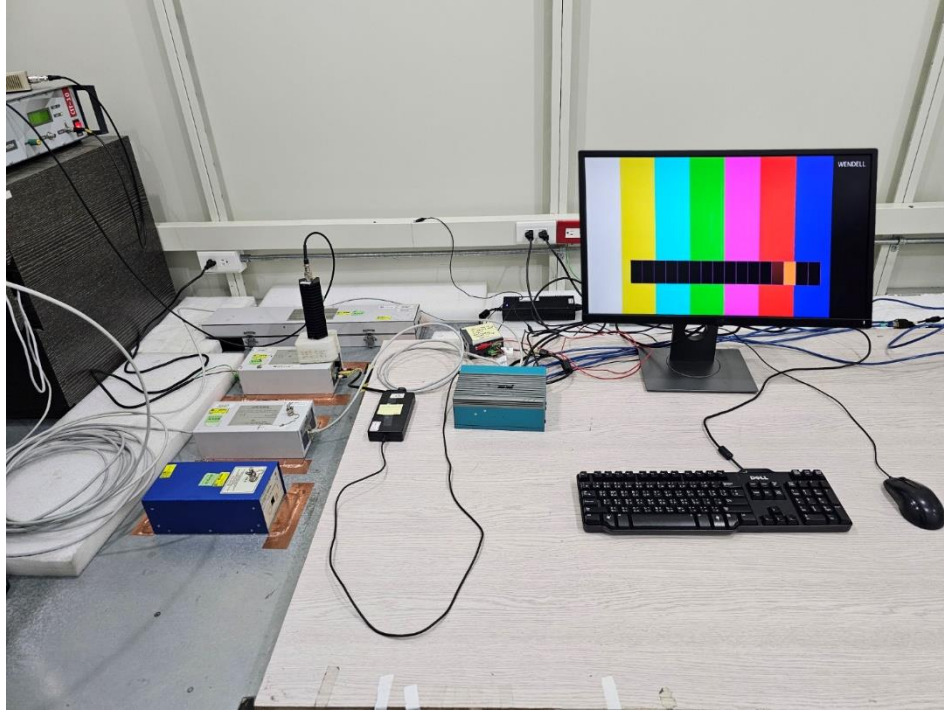

Signal

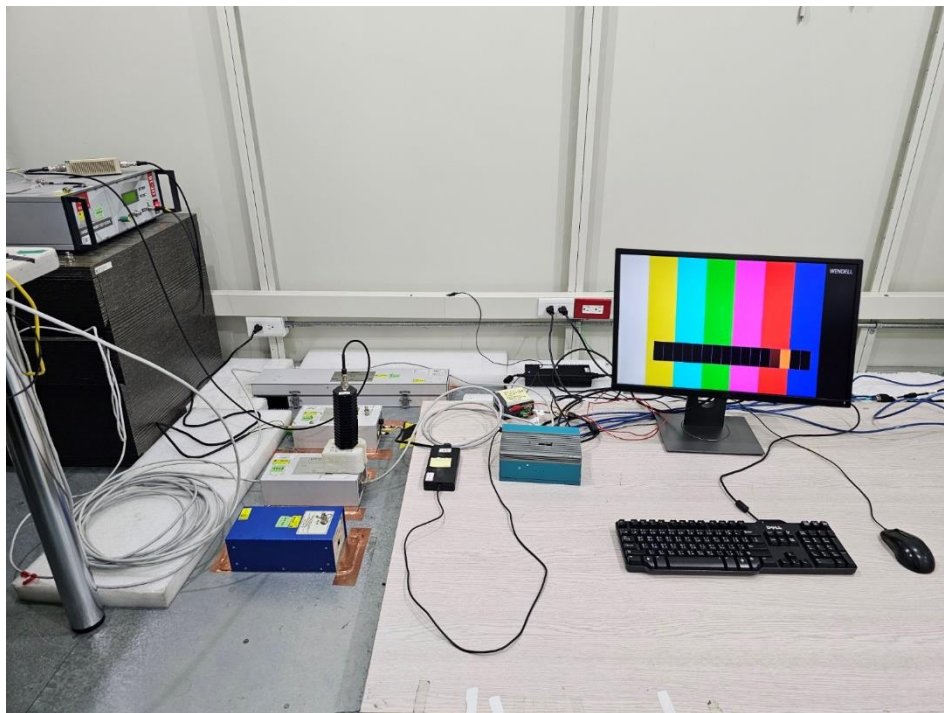

PoE

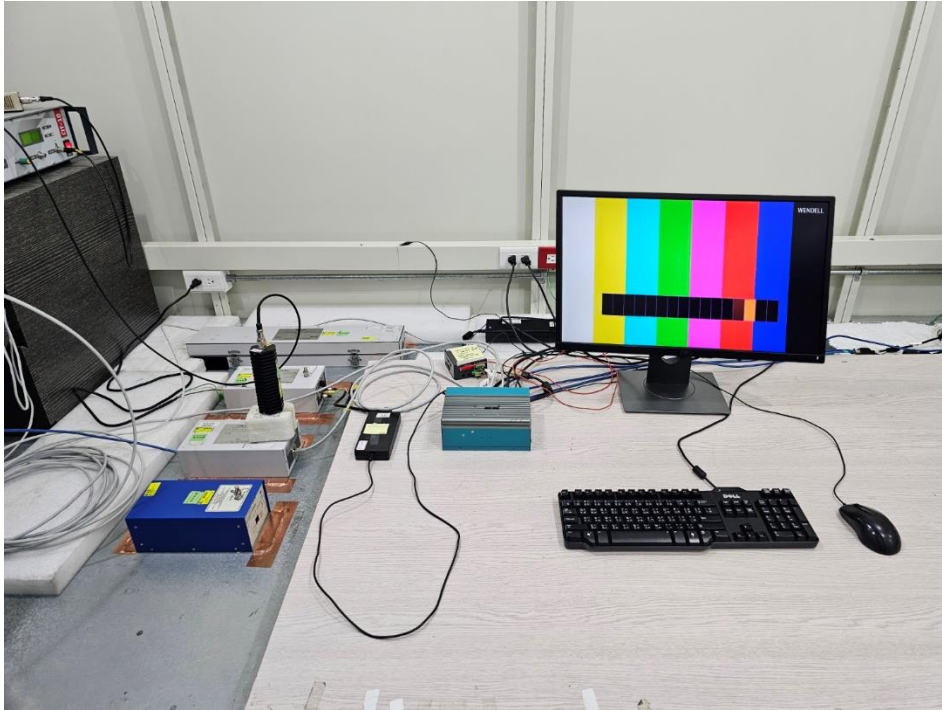

5.8 Power Frequency Magnetic Field Immunity Test

5.8.1 Test Specification

Standard	IEC/EN 61000-4-8
Frequency Range	50/60Hz
Field Strength	1 A/m
Observation Time	1 minute
Inductance Coil	Rectangular type, 1mx1m

Note: 1. Applicable only to equipment containing devices intrinsically susceptible to magnetic field, such as CRT monitors, Hall effect elements, electron-dynamic microphones, magnetic field sensors or audio frequency transformers.

5.8.2 Test Instrument

Item	Equipment	Manufacturer	Model	Meter No.	Calibration Date
1	PFMF	SGH	HMFG1000	CT-1-164	Sep. 28, 2023

Note: 1. The calibration interval of the above test instruments is 24 months.

5.8.3 Test Procedure

The table-top EUT was placed on a table which is 0.8 meter above a metal ground plane measured at least 1m x 1m minimum. The test magnetic field shall be placed at central of the induction coil. The floor-standing EUT was placed on 0.1m insulation support unit between the EUT and ground reference plane.

The test magnetic Field shall be applied 10 minutes by the immersion method to the table-top EUT, and the induction coil shall be rotated by 90° in order to expose the EUT to the test field with different orientation (X, Y, Z Orientations). The test magnetic Field shall be applied 10 minutes by the proximity method to the floor-standing EUT, and the induction coil shall be rotated by 90° in order to expose the EUT to the test field with different orientation (X, Y, Z Orientations).

5.8.4 Deviation from Test Standard

No deviation

5.8.5 Test Setup

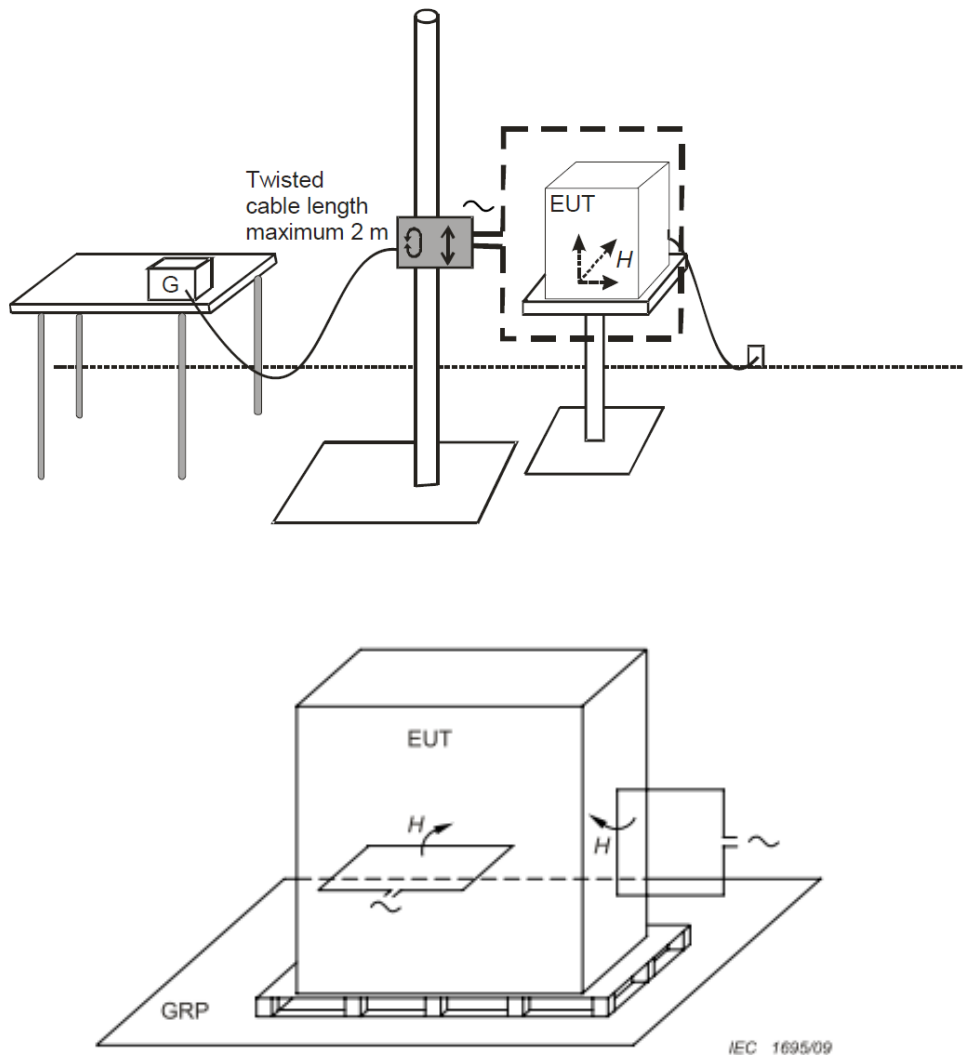

For the actual test configuration, please refer to 5.8.7.

NOTE:

TABLETOP EQUIPMENT

The equipment shall be subjected to the test magnetic field by using the induction coil of standard dimension (1 m x 1 m). The induction coil shall then be rotated by 90 degrees in order to expose the EUT to the test field with different orientations.

FLOOR-STANDING EQUIPMENT

The equipment shall be subjected to the test magnetic field by using induction coils of suitable dimensions. The test shall be repeated by moving and shifting the induction coils, in order to test the whole volume of the EUT for each orthogonal direction. The test shall be repeated with the coil shifted to different positions along the side of the EUT, in steps corresponding to 50 % of the shortest side of the coil. The induction coil shall then be rotated by 90 degrees in order to expose the EUT to the test field with different orientations.



5.8.6 Test Result

Test Voltage	230Vac, 50Hz	Environmental Conditions	22°C, 50% RH
Tested by	Alan Chung	Test Date	2024/07/03

Test Coil Position	Frequency (Hz)	Magnetic Strength (A/m)	Result
X - Axis	50/60	1	A
Y - Axis	50/60	1	A
Z - Axis	50/60	1	A

Note:

Criteria A: The EUT function was correct during the test.

5.8.7 Photographs of Test Configuration

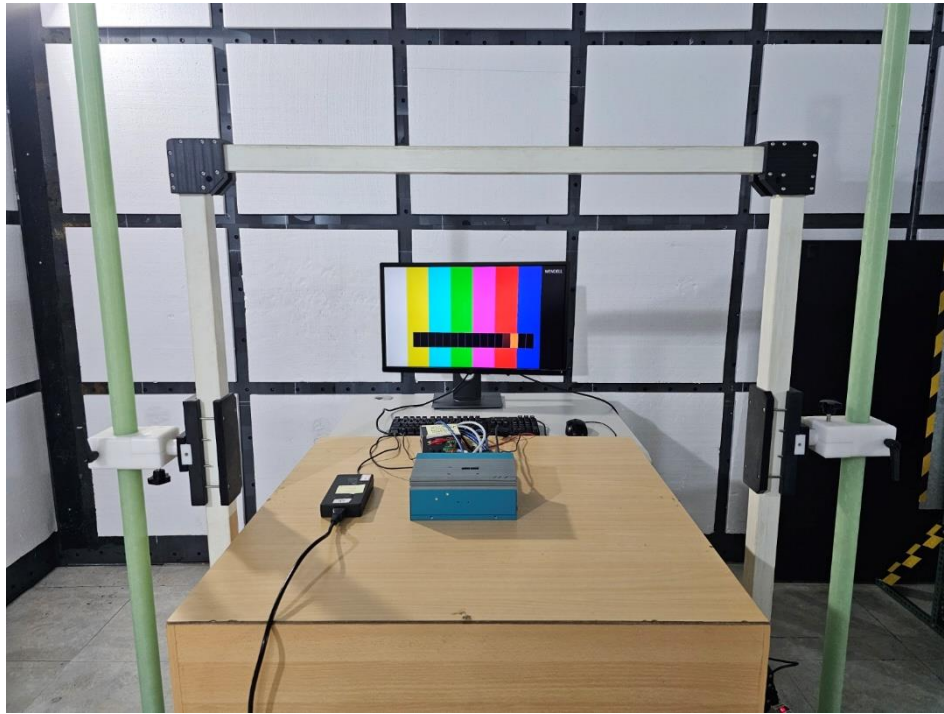

5.9 Voltage Dips & Short Interruptions

5.9.1 Test Specification

Basic Standard	IEC/EN 61000-4-11
Test Level	Voltage Dips: >95% reduction - 0.5 period 30% reduction - 25 period Voltage Interruptions: >95% reduction - 250 period
Test Duration Time	Minimum 3 test events in sequence
Interval between Event	Minimum 10 seconds
Phase Angle	0° / 180°
Test Cycle	3 times

Note: 1. Changes to occur at 0 degree crossover point of the voltage waveform. If the EUT does not demonstrate compliance when tested with 0 degree switching, the test shall be repeated with the switching occurring at both 90 degrees and 270 degrees. If the EUT satisfies these alternative requirements, then it fulfils the requirements. This condition shall be recorded in the test report.

5.9.2 Test Instrument

Item	Equipment	Manufacturer	Model	Meter No.	Calibration Date
1	DIP Simulator	3ctest	PFS2216S	CT-1-167	Sep. 20, 2023

Note: 1. The calibration interval of the above test instruments is 12 months.

5.9.3 Test Procedure

Before starting the test of a given EUT, a test plan shall be prepared.

The test plan should be representative of the way the system is actually used.

Systems may require a precise pre-analysis to define which system configurations must be tested to reproduce field situations.

Test cases must be explained and indicated in the Test report.

It is recommended that the test plan include the following items:

- the type designation of the EUT;
- information on possible connections (plugs, terminals, etc.) and corresponding cables, and peripherals;
- input power port of equipment to be tested;
- representative operational modes of the EUT for the test;
- performance criteria used and defined in the technical specifications;
- operational mode(s) of equipment;
- description of the test set-up.

If the actual operating signal sources are not available to the EUT, they may be simulated.

For each test, any degradation of performance shall be recorded. The monitoring equipment should be capable of displaying the status of the operational mode of the EUT during and after the tests. After each group of tests, a full functional check shall be performed.

5.9.4 Deviation from Test Standard

No deviation

5.9.5 Test Setup

< Table-Top equipment >

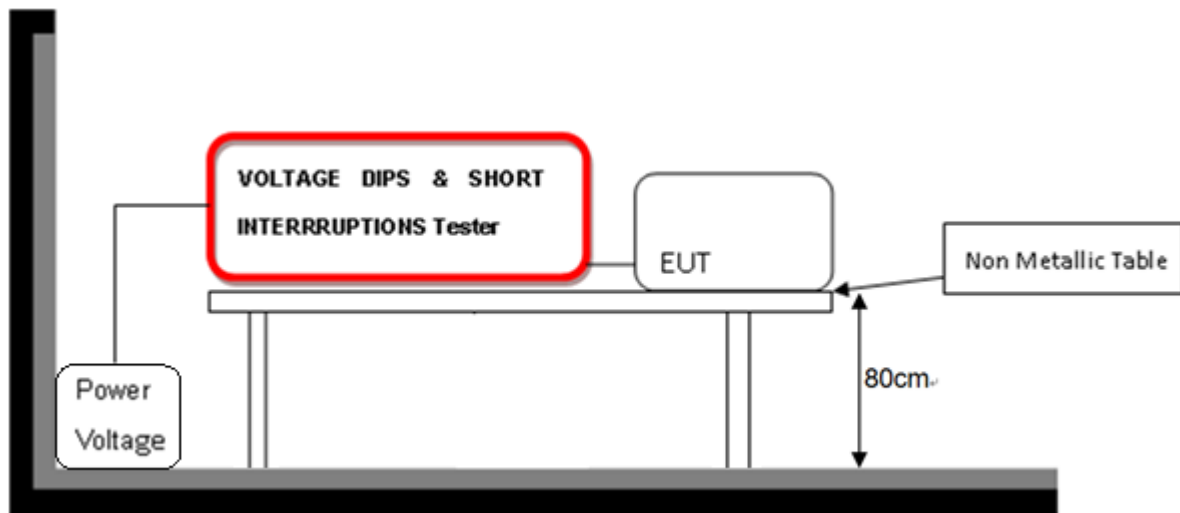

< Floor-Standing equipment >

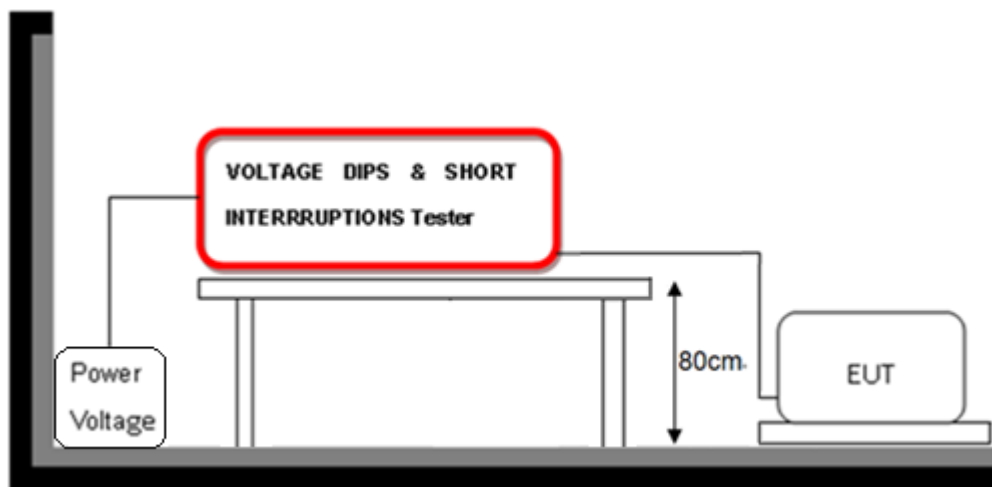



5.9.6 Test Result

Test Voltage	100-240Vac, 50Hz	Environmental Conditions	21°C, 52% RH
Tested by	Guanwei Liao	Test Date	2024/05/31

230Vac, 50Hz			
Test Item	% Reduction	Duration (Period)	Result
Voltage Dips	>95	0.5	A
	30	25	A
Voltage interruptions	>95	250	C (#1)

240Vac, 50Hz			
Test Item	% Reduction	Duration (Period)	Result
Voltage Dips	>95	0.5	A
	30	25	A
Voltage interruptions	>95	250	C (#1)

100Vac, 50Hz			
Test Item	% Reduction	Duration (Period)	Result
Voltage Dips	>95	0.5	A
	30	25	A
Voltage interruptions	>95	250	C (#1)

Note:

Criteria A: The EUT function was correct during the test.

Criteria C: (#1) The EUT was shut down during the test, and must be recovered manually.

5.9.7 Photographs of Test Configuration



< End Page >